

RL-35 Ring Clutch

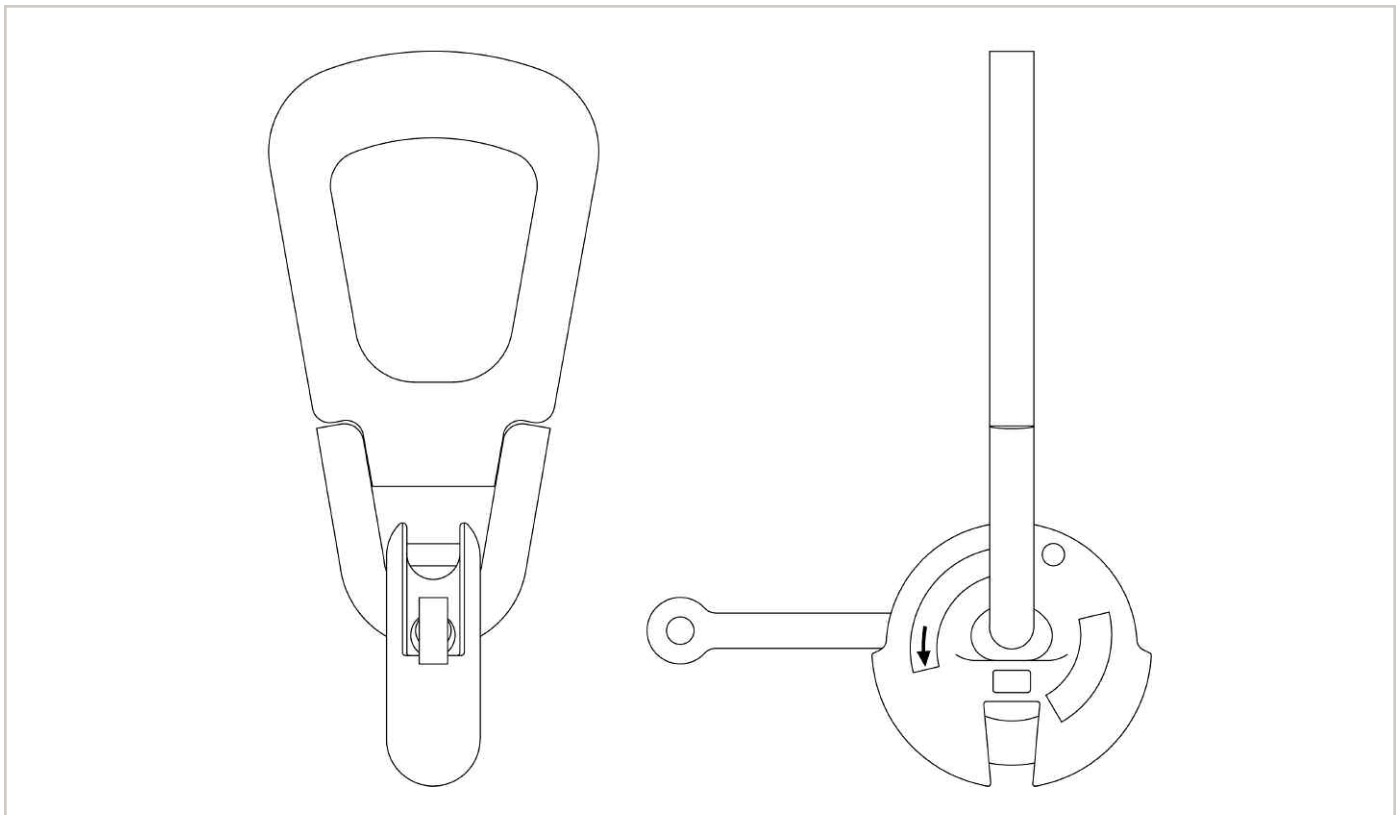

RL-35 RAPID LIFT RING CLUTCH DATA

Ring Clutch Systems	Clutch I.D.	Item Number	A	B	C	D	E	F	Weight Per Piece (lbs)	Clutch Capacity (ton)
2T/2.5T	2.5T	79001	10 7/16"	1 1/16"	3 1/8"	2 3/4"	2 1/4"	3 5/8"	3.65	2.5
4T/5T ¹	5T	79002	13"	1 7/16"	4 1/8"	3 3/16"	2 9/16"	4 1/2"	8.65	5
8T/10T ^{**}	10T	79003	16 3/4"	2"	5 15/16"	4 9/16"	3 9/16"	5 13/16"	19.87	10
22T/26T ²	26T	79170	23 7/8"	2 13/16"	8 1/4"	7 1/4"	4 3/4"	8 13/16"	55.0	22

- 1) Super Lift II Ring Clutch may be used, if a longer handle is required.
- 2) Available on special order or limited to quantity on hand. Special orders take 8 to 10 weeks.
- ** May be used with DTA (Double Tee Anchor), page 45.
- 3) Clutch capacities are rated at a 5:1 safety factor; and apply only to clutches manufactured after 1/1/2000.

The RL-35 Ring Clutch is an assembly consisting of a main clutch body, a curved bolt/handle and bail. The design of the ring clutch allows a full 360° rotation of the bail around the main body. The installation of the unit is quick and easy; simply rotate the curved bolt/handle to the open position, drop the main body into the anchor recess and rotate the bolt/handle to the closed position.

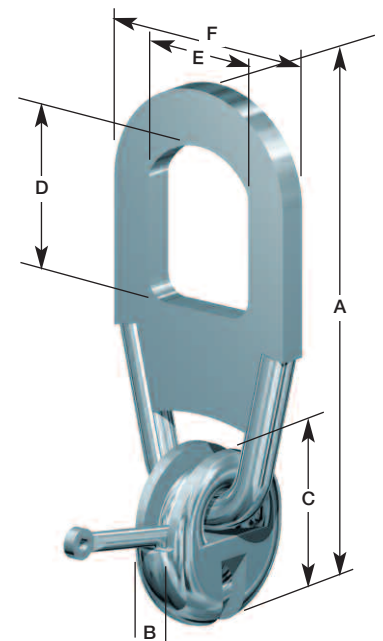

Distributed By

WESTECH RIGGING SUPPLY

Visit Us Online at: www.WestechRigging.com

Call Us Toll Free at: 800-442-7475

Call Us or Visit Our Stores: Monday - Friday, 8:00am - 5:30pm Pacific

4140 West 11th Avenue
Eugene, Oregon 97402

2439 McGilchrist St SE
Salem, Oregon 97302

