

# Crosby® Grade 100 SHUR-LOC® Hooks



Distributed By  
**WESTTECH RIGGING SUPPLY**

Visit Us Online at: [www.WesttechRigging.com](http://www.WesttechRigging.com)

Call Us Toll Free at: 800-442-7475

Call Us or Visit Our Stores: Monday - Friday, 8:00am - 5:30pm Pacific

4140 West 11th Avenue

Eugene, Oregon 97402

2439 McGilchrist St SE

Salem, Oregon 97302



**S-1316**  
Eye Hook



**S-1317**  
Clevis Hook

- Forged Alloy Steel - Quenched and Tempered.
- 25% stronger than Grade 80.
- Individually Proof Tested to 2-1/2 times the Working Load Limit with certification.
- Recessed trigger design is flush with the hook body, protecting the trigger from potential damage.
  - Easy to operate with enlarged thumb access.
- Positive Lock Latch is Self-Locking when hook is loaded.
- Eye style is designed with "Engineered Flat" to connect to S-1325 chain coupler.
- Suitable for use with Grade 100 and Grade 80 chain.
- The SHUR-LOC® hook, if properly installed and locked, can be used for personnel lifting applications and meets the intent of OSHA Rule 1926.1431(g)(1)(i)(A) and 1926.1501(g)(4)(iv)(B).
- Fatigue rated at 1-1/2 times the Working Load Limit at 20,000 cycles.
- "Look for the Platinum Color - Crosby Grade 100 Alloy Products."
- Forged Alloy Steel - Quenched and Tempered.
- 25% stronger than Grade 80.
- Individually Proof Tested to 2-1/2 times the Working Load Limit with certification.
- Recessed trigger design is flush with the hook body, protecting the trigger from potential damage.
  - Easy to operate with enlarged thumb access.
- Positive Lock Latch is Self-Locking when hook is loaded.

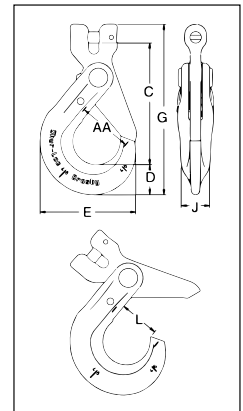
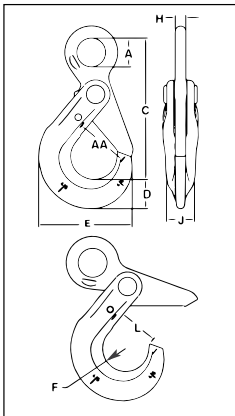

## SHUR-LOC® Hook Series with Positive Locking Latch S-1316 Eye Hook

Chain Size		Working Load Limit (lbs.)*	S-1316 Stock No.	Weight Each (lbs.)	Dimensions (in.)								
(in.)	(mm)				A	C	D	E	F	H	J	L	AA
-	6	3200	1022896	.85	.78	3.95	.79	2.60	.67	.31	.63	1.14	1.50
1/4-5/16	7-8	5700	1022914	1.80	1.08	5.31	1.10	3.50	.87	.39	.81	1.48	2.00
3/8	10	8800	1022923	3.40	1.30	6.57	1.17	4.39	1.10	.51	.94	1.83	2.50
1/2	13	15000	1022932	6.00	1.65	8.23	1.67	5.45	1.26	.67	1.16	2.22	3.00
5/8	16	22600	1022941	15.1	2.20	10.06	2.04	6.56	1.50	.87	1.50	2.65	3.50
3/4	18-20	35300	1022942	19.0	2.60	10.77	2.22	7.76	2.01	.87	2.03	3.52	-
7/8	22	42700	1022943	28.0	2.87	12.49	2.45	8.75	2.27	.98	2.20	3.83	-
1	26	59700	1022944	49.5	3.15	14.60	3.21	9.87	2.46	1.26	2.68	4.09	-

\* Minimum Ultimate Load is 4 times the Working Load Limit.

## S-1317 Clevis Hook

Chain Size		Working Load Limit (lbs.)*	S-1317 Stock No.	Weight Each (lbs.)	Dimensions (in.)						
(in.)	(mm)				C	D	E	G	J	L	AA
-	6	3200	1028991	.77	3.44	.79	2.60	4.75	.63	1.16	1.50
1/4	7	4300	1029000	1.80	4.48	1.10	3.51	6.25	.81	1.48	2.00
5/16	8	5700	1029009	1.80	4.47	1.10	3.51	6.25	.81	1.48	2.00
3/8	10	8800	1029018	3.66	5.53	1.17	4.39	7.54	.94	1.83	2.50
1/2	13	15000	1029027	6.80	6.81	1.67	5.49	9.52	1.16	2.22	3.00
5/8	16	22600	1029036	11.9	8.22	2.04	6.55	11.61	1.50	2.65	3.50
3/4	18-20	35300	1029071	15.0	9.42	2.22	7.76	13.21	2.03	3.52	-
7/8	22	42700	1029080	28.0	11.14	2.45	8.75	15.45	2.20	3.83	-
1	26	59700	1029089	49.5	12.56	3.21	9.87	18.44	2.68	4.09	-

\* Minimum Ultimate Load is 4 times the Working Load Limit.

# Crosby® SHUR-LOC® HOOKS

## WARNING & APPLICATION INSTRUCTIONS



### Important Safety Information - Read and Follow

- A visual periodic inspection for cracks, nicks, wear, gouges and deformation as part of a comprehensive documented inspection program, should be conducted by trained personnel in compliance with the schedule in ANSI B30.10.
- For hooks used in frequent load cycles, pulsating loads, or severe duty as defined by ASME B30.10, the hook and threads should be periodically inspected by Magnetic Particle or Dye Penetrant. (Note: Some disassembly may be required.)
- Never use a hook whose throat opening has been increased 5%, not to exceed 1/4" (6mm) or shows any visible apparent bend or twist from the plane of the unbent hook, or is in any other way distorted or bent. **NOTE: A latch will not work properly on a hook with a bent or worn tip.**
- Never use a hook that is worn beyond the limits shown in Figure 1.
- Remove from service any hook with a crack, nick, or gouge. Hooks with a nick or gouge shall be repaired by grinding lengthwise, following the contour of the hook, provided that the reduced dimension is within the limits shown in Figure 1. Contact Crosby Engineering to evaluate any crack.
- Never repair, alter, rework, or reshape a hook by welding, heating, burning, or bending.
- Never side load, back load or tip load a hook. Side loading, back loading and tip loading are conditions that damage and reduce the capacity of the hook. (See Figure 2)
- S-1326A can be used for limited rotations under load (infrequent, noncontinuous).
- Efficiency of synthetic sling material may be reduced when used in eye or bowl of hook.
- Always make sure the hook supports the load. (See Figure 3).
- Do not use hook tip for lifting (See Figure 4).
- When placing two (2) sling legs in hook, make sure the angle from vertical to the leg nearest the hook tip is not greater than 45 degrees, and the included angle between the legs does not exceed 90 degrees\* (See Figure 5).

## WARNING

- Loads may disengage from hook if proper procedures are not followed.
- A falling load may cause serious injury or death.
- Positive locking latch will unlock when trigger is depressed. Never use hook unless hook and latch are fully closed and locked.
- Keep body parts clear of pinch point between hook tip and hook latch when closing.
- Keep hand(s) from between throat of hook and sling or other device.
- Do not use hook tip for lifting.
- Do not use hook handle for lifting.
- Shank threads may corrode and/or strip and drop the load.
- Remove securement nut to inspect threads for corrosion or to replace S-1326A bearing washers (2) and or S-13326 thrust bearing.
- Never apply more force than the hook's assigned Working Load Limit (WLL) rating.
- See OSHA Rule 1926.1431(g) and 1926.1501(g) for personnel hoisting by cranes or derricks. A Crosby 1318A, 1326A, 13326, 1316A, or 1317A hook may be used for lifting personnel.
- Use only genuine Crosby parts as replacements.
- Read and understand these instructions before using hook.

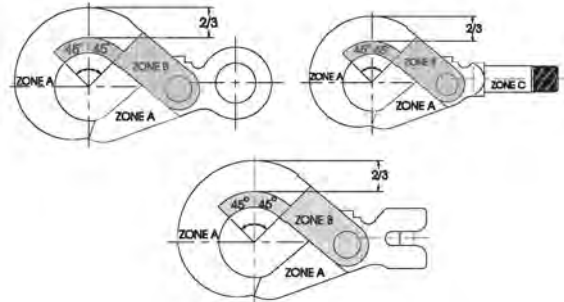

ZONE A: 10% OF ORIGINAL DIMENSION  
 ZONE B: 5% OF ORIGINAL DIMENSION  
 ZONE C: SEE MINIMUM THREAD SIZE CHART

FIGURE 1

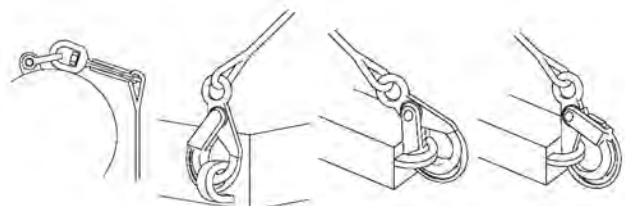

Side Load Wrong      Side Load Wrong      Back Load Wrong      Tip Load Wrong

FIGURE 2



\* For two legged slings with angles greater than 90°, use an intermediate link such as a master link or bolt type shackle to collect the legs of the slings. The intermediate link can then be placed over the hook to provide an in-line load on the hook. This approach must also be used when using slings with three or more legs.

- See ANSI/ASME B30.10 “Hooks” for additional information.
- The hook handle of the 1316AH is for manipulation only and not intended to carry a load.

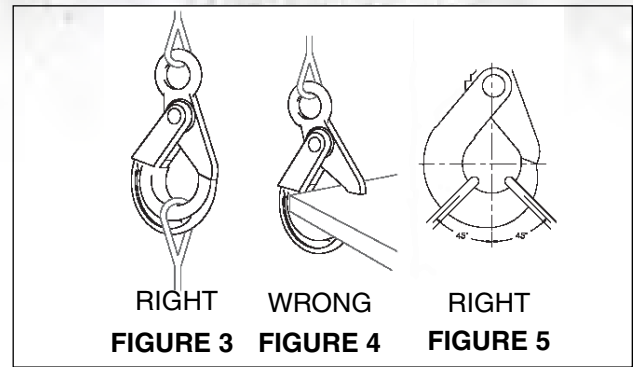

### Important Basic Machining and Thread Information: Read and Follow

- Wrong thread and/or shank size can cause stripping and loss of load.
- The maximum diameter is the largest diameter, after cleanup, that could be expected after allowing for straightness, pits, etc.
- All threads must be Class 2 or better.
- The minimum thread length engaged in the nut should not be less than one (1) thread diameter.
- Hook shanks are not intended to be swaged on wire rope or rod.
- Hook shanks are not intended to be drilled (length of shank) and internally threaded.
- Crosby cannot assume responsibility for, (A) the quality of machining, (B) the type of application, or (C) the means of attachment to the power source or load.
- Consult the Crosby Hook Identification & Working Load Limit Chart (See below) for the minimum thread size for assigned Working Load Limits (WLL). †
- Remove from service any Hook which has threads corroded more than 20% of the nut engaged length.

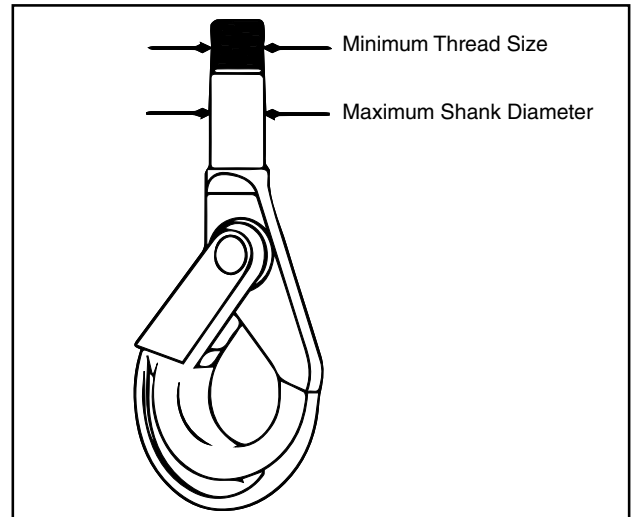

### Crosby® Hook Identification & Working Load Limit Chart†

S-1316A & S-1317A Only Grade 100 Chain			S-1318AH, S-1326A, S-13326					S-1318A Only † †		
Chain Size		Working Load Limit (lbs.)** 4:1	Grade 100 Chain			Wire Rope XXIP Mechanical Splice		Maximum Shank Diameter		Minimum Thread Size (in.)
(in.)	(mm)		Chain Size	Working Load Limit (lbs.)** 4:1	Wire Rope Size (in.)	Working Load Limit (lbs.)* 5:1	(in.)	(mm)		
—	6	3200	—	6	3200	5/16	2200	.72	18	5/8 - 11 UNC
1/4	7	4300	1/4	7 - 8	4300	7/16	4200	.94	24	5/8 - 11 UNC
5/16	8	5700	5/16	8	5700	7/16	4200	.94	24	3/4 - 10 UNC
3/8	10	8800	3/8	10	8800	1/2	5600	1.06	27	3/4 - 10 UNC
1/2	13	15000	1/2	13	15000	5/8	8600	1.19	30	1-1/8 - 7 UNC
5/8	16	22600	5/8	16	22600	7/8	16600	1.38	35	1-3/8 - 6 UNC
3/4	18/20	35300	3/4	18-20	35300	1	22000	—	—	—
7/8	22	42700	7/8	22	42700	1-1/8	26500	—	—	—
1	26	59700	1	26	59700	1-1/4	32500	—	—	—

\* Ultimate Load is 5 times the Working Load Limit based on XXIP Wire Rope.

\*\* Ultimate Load is 4 times the Working Load Limit based on Grade 100 Chain.

† Working Load Limit - The maximum mass of force which the product is authorized to support in general service when the pull is applied in-line, unless noted otherwise, with respect to the centerline of the product. This term is used interchangeably with the following terms: 1. WLL, 2. Rated Load Value, 3. SWL, 4. Safe Working Load, 5. Resultant Safe Working Load.

† † Based on minimum thread size for assigned WLL.