

CAT CDMA

SKU: IPD-CAT-CDMA

Cellular Alarm Communicator



connected by
verizon



Installation Manual

CAT CDMA

QUICK REFERENCE

DSC:

Programming of DSC:

Section	Cellular CAT CDMA as Sole Communicator
301	Enter Phone Number
310	Enter Account Number
350	Enter '03/03' for Contact ID

Honeywell VISTA:

Programming of Honeywell Vista:

Section	Cellular CAT CDMA as Sole Communicator
*41	Enter Phone Number
*43	Enter Account Number

GE:

Programming of GE NetworX:

Section Device 0	Cellular CAT CDMA as Sole Communicator
Location 0	Enter the Phone Number
Location 1	Enter Account Number
Location 2	Enter '13' for Contact ID

Technical Support Information

For Technical Support, call toll free: **866-896-2944**
Hours: Monday - Friday 7a - 6:30p CST
mail: **techsupport@ipdatatel.com**
Web: **www.ipdatatel.com**
www.alarmdealer.com
setup.alarmdealer.com - used to view device information

ipDatatel, LLC
13110 Southwest Freeway
Sugar Land, TX 77478
Toll Free: 866-896-2944

Table of Contents

Quick Reference	2
Getting Started	3
• Pre-Installation	3
• Installation Guide	3
DSC Panel Wiring and Programming	6
• DSC Programming Charts	8
Honeywell Vista Panel Wiring and Programming	10
• Honeywell Vista Programming Charts	11
GE Panel Wiring and Programming	12
• GE Panel Programming Chart	12
Generic Alarm Panel Wiring and Programming	13
Supported Panels Charts	15
Specifications	17

Installation Guide

General Considerations

- Before installation, your Cellular CAT must be setup using the dealer branded Portal located at: www.alarmdealer.com.
- The Product should be installed securely within the supplied plastic housing and mounted next to the alarm control panel.
- Choose a location with good Cellular reception by monitoring the Product's signal strength LEDs utilizing a temporary power wire.
- Power the Product down before mounting / installation.
- Programming of the alarm control is fairly simple. Written instructions are included in the "Wiring & Programming" section of this manual.

Pre-Installation

Create Account Wizard

Before the installation of your Cellular CAT, the Product must be registered through ipDatatel at: www.alarmdealer.com.

Here are the steps needed to register the Cellular CAT:

- Log in to alarmdealer.com with the dealer login information that was emailed to you.
- Click Create Account Wizard
- Follow the 4-Step Wizard

Locating and Installing the Cellular CAT

The Product connects to the alarm panel's power connections, Telco, and key-switch connections (optional).

Telco - Digital Dialer

The Cellular CAT's signal collection requires Contact ID format transmit from the digital dialer of the alarm control. Wire the Telco side of the alarm control's Tip & Ring to the Product's Tip & Ring. Obviously, you must remove the POTS line (if any) from the alarm control as it would interfere with the installation of the Product.

Virtual Key-Switch Connection

The Cellular CAT can connect to most panels and provide a Virtual Key-Switch, allowing the customer to use the arm/disarm function. Virtual Key-Switch access is obtained after the customer authenticates using the customer username and password you have assigned them in the pre-installation phase. The customer will then need to download the SecureSmart app from their smart- phone. Additionally, the customer can also obtain access through a web interface. The Virtual Key-Switch is an option, and is not required to for alarm signal transmission from the Cellular CAT.

Power Connection

The final step is to wire the alarm panel's 12VDC auxiliary positive and negative power to the Product's positive (pin 4) and negative (pin 3) terminals.

Basic Programming

The Cellular CAT simulates a POTS telephone service to the panel. General programming for the control requires configuring the signal format as Contact ID, and inputting a telephone number to dial. The telephone number can be arbitrary (555-555-5555).

Validating the Installation

After the Cellular CAT is properly powered and connected to the alarm control, use the following steps to validate that the system is functioning properly:

- Ensure that all alarm signals are received by your central station.
- Ensure that virtual key-switch functionality works through the SecureSmart mobile app, and/or the web at: www.alardealer.com

Cellular CAT (CDMA) Service Provisioning

All new Cellular CAT's are pre-provisioned with Verizon, which means they are linked to the network and no additional steps are required for this Product to come online.

Re-Provisioning (If necessary)

If you are installing a Cellular CAT that was previously installed, you may need to perform a re-provisioning of the OTAP, which is required by Verizon to make the Product come online. If a Cellular CAT is removed or deactivated from an account, you will need to make sure it is re-provisioned. To re-provision the Cellular CAT, please follow these steps:

OTAP Steps (If Needed)

1. To begin, ensure that the Product is powered appropriately with 12- volts either from a battery or the control panel.
2. Press and release the SW1 switch 3 times (i.e. triple click the switch),
3. Once released, the Product will auto power cycle. When it re-initializes you should see LEDs 3 - 6 scrolling,
4. Once acquired into the network, you will see the signal strength indicated on the board via LEDs 3 - 6.
5. Wait approximately 5 minutes before sending signals.
6. Verify LED 1 light is solid

Wiring & Programming for Popular Panels

The following pages are organized by alarm panel type. Wiring and programming instructions are provided for:

- Digital Security Control (DSC) Alarm Panels
- Honeywell Vista Alarm Panels
- GE NetworX Alarm Panels

DSC Panel Wiring and Programming

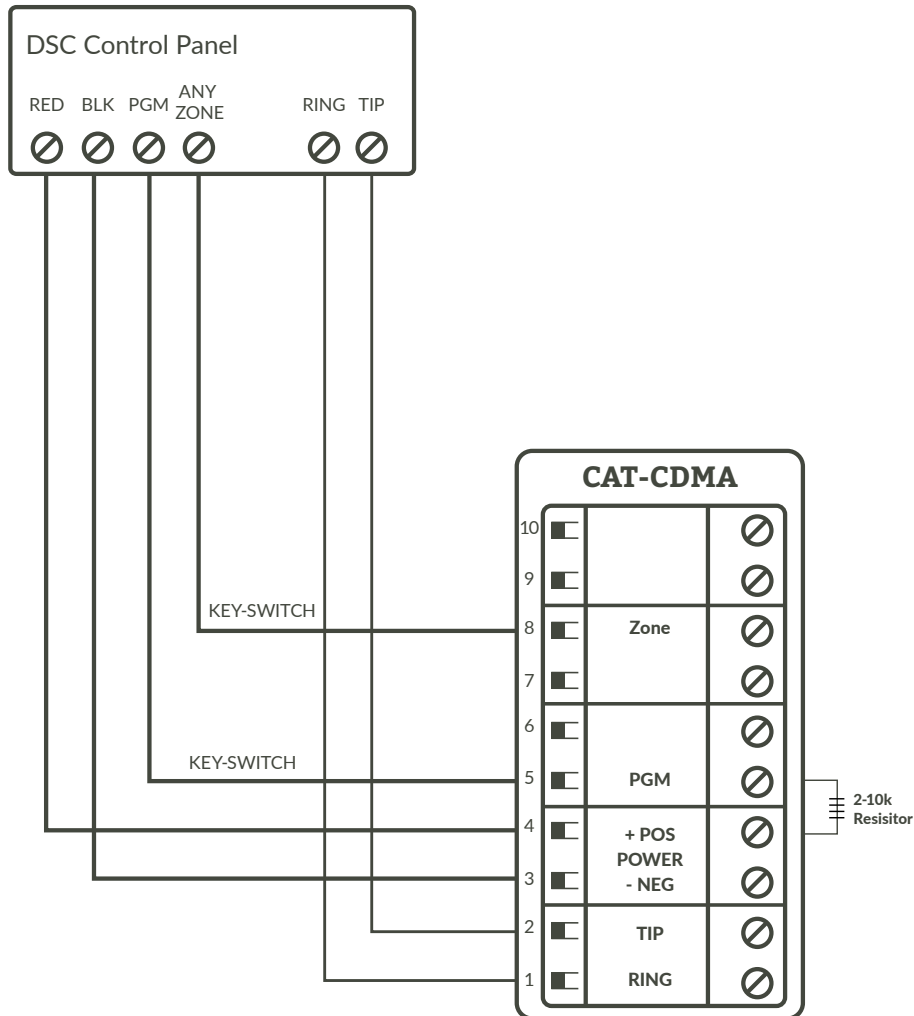

DSC Control Wiring & Key-Switch Option

General Concept for programming a DSC panel for the Cellular CAT as a Sole Communicator, and keyswitch for remote Arm/Disarm using SecureSmart mobile app:

Section	As Sole Communicator	Code Summarization
301	Enter Phone Number	
310	Enter Account Number	
350	Enter '03' to send Contact ID	Panel default is '04', SIA
367	Turn on option '1'	Open/closing

Note: Ensure All Report Codes are in and signals can be sent.

Section	As Keyswitch	Code Summarization
001	Set Zone as '22'	Momentary Keyswitch Arm
009	Set PGM as '05'	Armed Status

Note: The CAT CDMA unit will require a panel resistor from Terminal 4 (POS) to 5 (PGM). This will indicate the correct change of state.

Honeywell Vista Panel Wiring and Programming

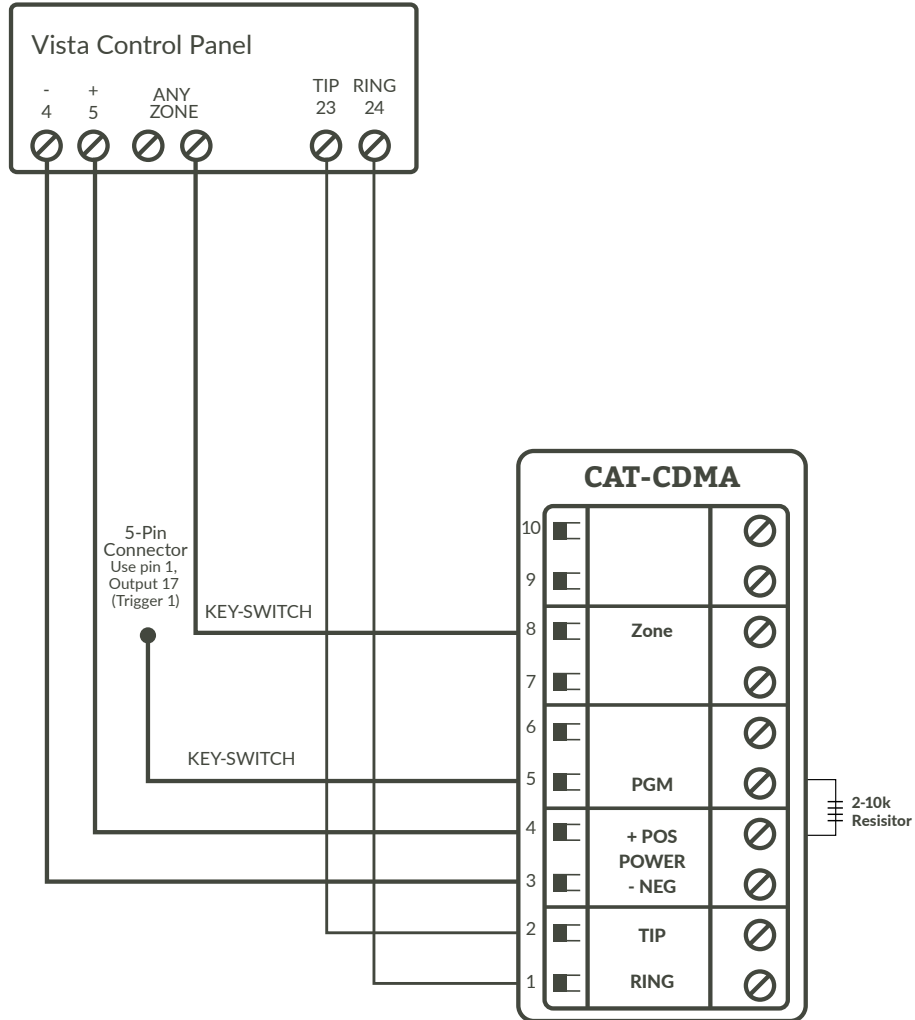

Honeywell Vista Control Wiring & Key-Switch Option

Note: Key-Switch programming is available for Vista-15 and up.

General Concept for programming a Honeywell Vista panel for the Cellular CAT as a Sole Communicator:

Section	As Sole Communicator	Code Summarization
41	Enter Phone Number	
43	Enter Account Number	
65 & 66	Enter 1	If you wish to receive Opening/Closing Reports

Note: The CAT CDMA unit will require a panel resistor from Terminal 4 (POS) to 5 (PGM). This will indicate the correct change of state.

GE Panel Wiring and Programming

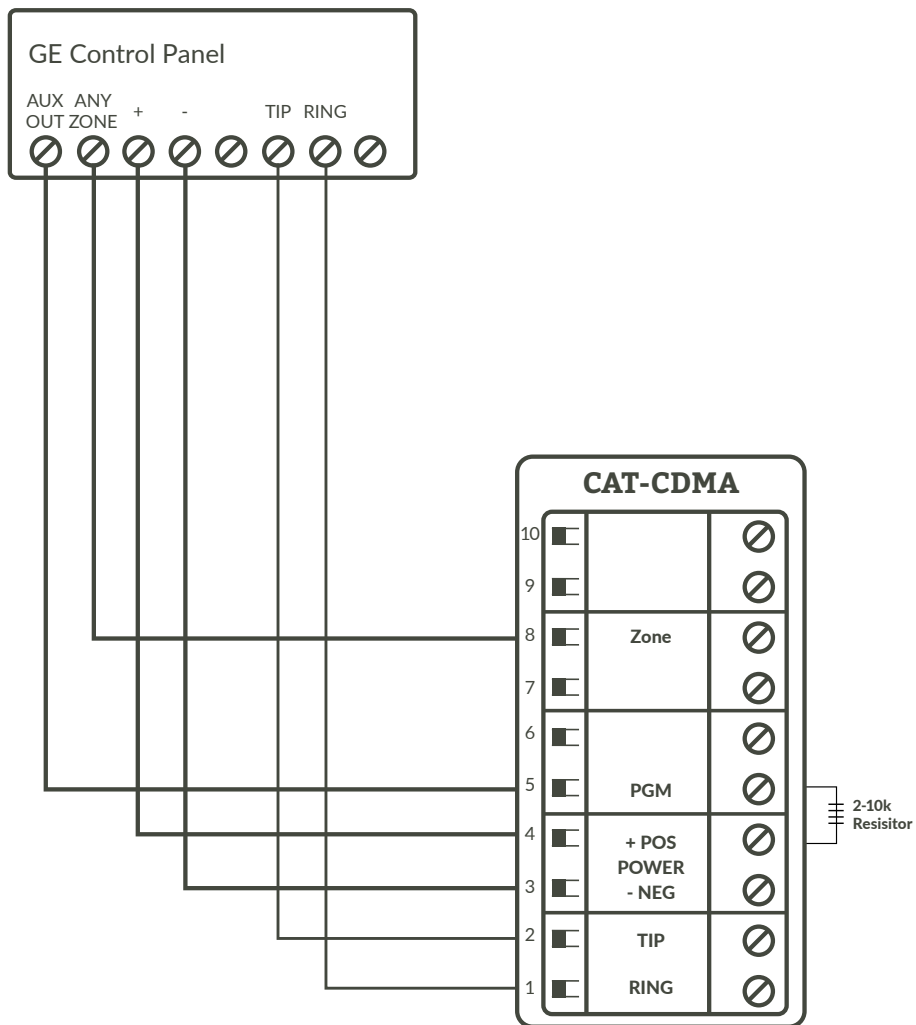

GE Control Wiring & Key-Switch Option

General Concept for programming a GE NetworX panel for the Cellular CAT as a Sole Communicator::

Section	As Sole Communicator	Code Summarization
Device 0, Location 0	Enter Phone Number	
Device 0, Location 1	Enter Account Number	
Device 0, Location 2	Enter '13' Recommended value	Contact ID

Note: The CAT CDMA unit will require a panel resistor from Terminal 4 (POS) to 5 (PGM). This will indicate the correct change of state.

Generic Alarm Panel Wiring and Programming

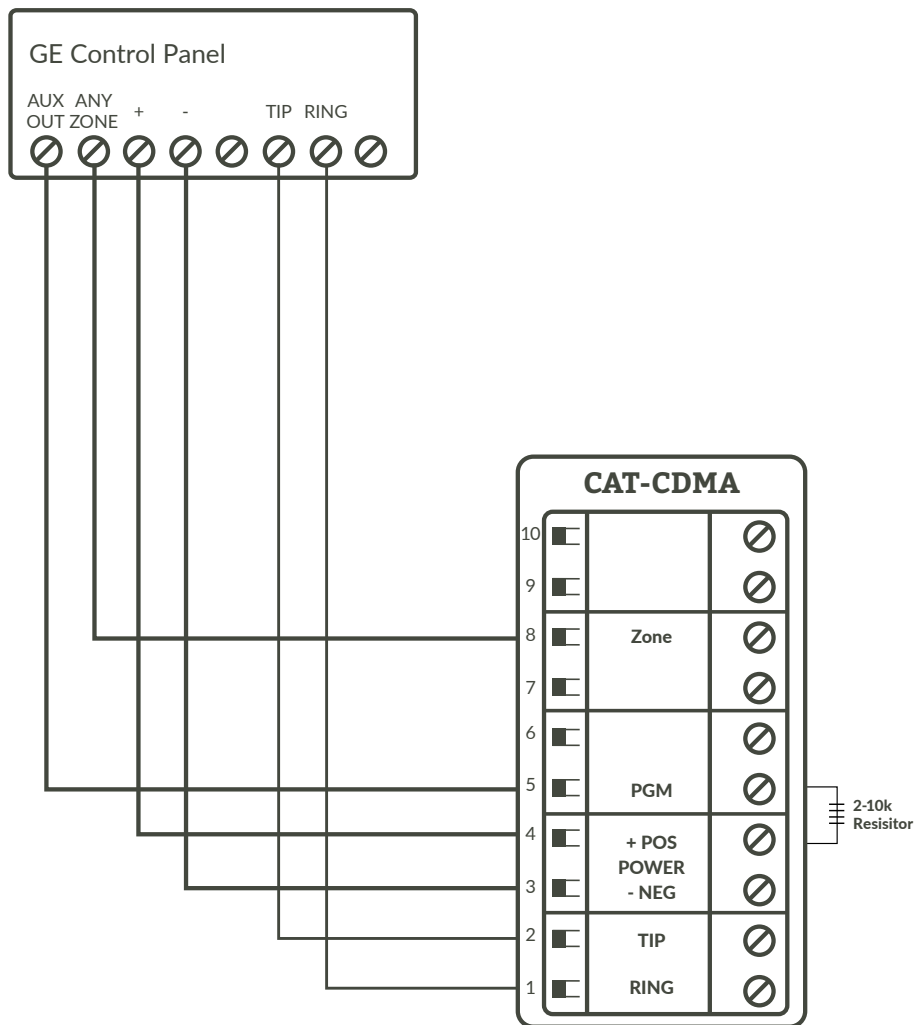

For basic Key-Switch operation with the Cellular CAT, the following alarm panel wiring is needed.

- A programmable output on the alarm panel will be used to signal to the Product (PGM Terminal 5) that the panel has entered Arm/Disarmed state.
- The zone (Terminal 8) output on the Product will be used as a Key-Switch connection to a 'zone' terminal on the alarm panel.

General Concept: Key-Switch Programming

Key-Switch programming examples for Honeywell, DSC, and GE NetworX are provided in the following paragraph. Most panel manufacturers will have the capability to configure a zone for key-switch operation and generally have at least one on-board programmable output that can be configured to activate on a number of different controls state conditions. Please reference the alarm panel installation manual for details for your specific installation.

Honeywell Vista (General Concept)

1. *56 Program zone as type 77
2. Partition # 1
3. Report Code 01 00
4. EOL 0 (can be 2 depending on panel)
5. Resp Time 1
6. *79 output 17
7. Set 0 for normally low
8. *00 quit
9. *80 field 80
10. Output function 17
11. * Twice
12. Activated by 2
13. Zone type 78
14. Key-Switch red* partition 1
15. *Output number 17
16. **Output function 18
17. Activated by 2
18. Zone type 79
19. Key-Switch green
20. Output still 17

DSC PowerSeries (General Concept)

Program Zone (Section 001) as '22'

Program PGM Output (Section 009) as '5'

DSC Alexor (General Concept) Wiring:

CAT - Terminal 8 (Zone) → I/02 - Panel CAT - Terminal 5 (PGM) → I/01 - Panel

CAT - 6.2k ohms resistor from Term 4 (Positive) → Terminal 5 (PGM)

DSC Alexor (General Concept) Programming:

Section 009 - '05'/'22'

Section 013 - Enable 2 & Disable 1

Section 134 - Enable 14 (Press 9, then 6 on, 7 off) normally closed.

Section 206 - Enable 2

Section 501 - Enable 3

GE NetworX (General Concept)

Stay in Device '0' Go to location 25

Program zone as '11' LED Status

Location 47 Segment 1: 21

Location 47 Segment 2: 0

Testing:

It is highly recommended that you test every alarm signal that the control panel is designed to transmit to ensure correct programming of the alarm control, Cellular CAT, and central station devices.

Specifications

Radio

- Frequencies CDMA 1x
800 MHz/1900 MHz

Power

- Externally Provided 12v DC
- Typical Current Draw 130 mA
- Max Current Draw 180 mA

Environmental

- Temperature Range - 22° to +158° F (- 30° to +70° C)
- Humidity 0 to 95% non-condensing

Physical

- Height 4.125 Inches (with antenna stub)
- Width 2.4375 Inches
- Depth .5 Inch

With Case

- Height 5.18 Inches
- Width 3 Inches
- Depth 1.5 Inches

Troubleshooting Diagnostic Information

LED – 1: Status:

- Normal Operating – Solid when connected to network.
- Blinks 3 times if not connected to network.
- Blinks 4 times when initializing over the network.

LED – 2: Activity:

- Normal Operating – Light is not illuminated.
- Blinks when there is a pending signal.

LED – 3: Connection:

- Blinks until the Cellular CAT has been initialized and will remain solid after connection to Verizon is complete.

LEDs – 3 to 6: Verizon Signal Strength

- LED 3 being the lowest and LED 6 being the highest signal strength. The minimum recommended operation is two bars (LEDs 3 & 4 Solid)



ipDatatel, LLC.
13110 Southwest Freeway
Sugar Land, Texas 77478

Main: 713.452.2700
Toll Free: 866.896.2944

www.ipdatatel.com

* All product and company names are trademarks™ or registered® trademarks of their respective holders. Use of them does not imply any affiliation with or endorsement by them.