

SWIT®

Model: **M-1071F**

7"×2 Rack Mount HDSDI&HDMI LCD Monitor

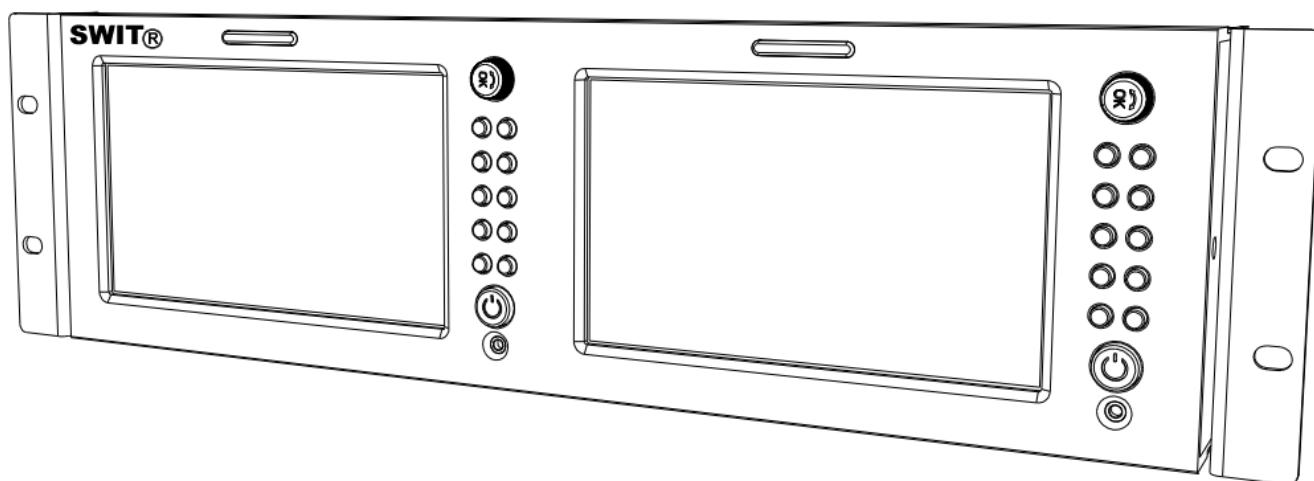

User Manual

Please read this User Manual
throughout before using.

Preface

Congratulations on your purchase of this product. Please read this user manual carefully.

1. All internal technologies of this product are protected, including device, software and trademark. Reproduction in whole or in part without written permission is prohibited.
2. All brands and trademarks of SWIT Electronics Co., Ltd. are protected and other relative trademarks in this user manual are the property of their respective owners.
3. Due to constant effort of product development, SWIT reserves the right to make changes and improvements to the product described in this manual without prior notice.
4. The warranty period of this product is 2 years, and does not cover the following:
 - (1) Physical damage to the surface of the products, including scratches, cracks or other damage to the LCD screen or other externally exposed parts;
 - (2) Misuse, abuse or negligent operation to the product;
 - (3) The product is disassembled by anyone other than an authorized service center.It is considered normal that the LCD bright dot defects are not to exceed three.
5. For any suggestions and requirements on this product, please contact us through phone, fax, Email, etc.

SWIT Electronics Co., Ltd.

Address: 10 Hengtong Road, Nanjing Economic and Technological Development Zone,
Nanjing 210038, P.R.China

Phone: +86-25-85805753

Fax: +86-25-85805296

Email: contact@swit.cc

Website: <http://www.swit.cc>

Maintenance

- **The Monitor**

1. Please keep the signal terminals and the cooling vent away from knife-edge, metal or liquid in order to avoid short-circuit and damage.
2. Please don't try to disassemble any parts of the monitor by yourself, which would probably damage the monitor and do harm to human body, and it will cause the invalidation of product warranty.
3. Please don't touch the screen with your fingers, which would probably deface the screen.
4. Please don't press the screen; the LCD is extremely exquisite and flimsy.

- **The power**

Please use the power adapter provided or recommended by the manufacturer in order to avoid damage. For a third party power adapter, please make sure the voltage range, supplied power, and polarity of power lead are fit.

Please disconnect the power cable under the following situations:

1. If you do not operate this monitor for a period of time;
2. If the power cable or power adaptor is damaged;
3. If the monitor housing is broken.

- **Working Environment**

1. Please don't lay this product on the unstable place.
2. Please don't lay this product in hot, cold or wet location.

- **Cleaning**

1. Please clean the screen with dry and downy cloth or special LCD cleanser.
2. Please do not press hard when cleaning the screen.
3. Please do not use water or other chemical cleanser to clean the screen. The chemical may damage the LCD.
4. For first time use, please tear off the factory LCD film. To protect the LCD screen, please post the LCD protection film offered in the package.

1. Features

◆ **New high resolution 7" LCD Panel**

Consists of two 7-inch, 16:9, 1024×600 LCD panels, with 900:1 contrast, H/V 160° wide viewing angle, and 19-inch 3U rack mount,

◆ **Multiple inputs**

HD/SD-SDI, HDMI and Composite input

◆ **Loop through outputs**

Each of the 2 input HD/SD-SDI and HDMI has loop through output.

◆ **HDMI converted to SDI output**

Supported HDMI formats: 480i / 576i / 720p (50, 59.94, 60) / 1080i (50, 59.94, 60) / 1080P (23.98 24, 25, 29.97, 30), and the output SDI will embed the audio (48KHz) from HDMI.

◆ **Waveform (Y, Cb, Cr, R, G, B) and full scale**

There are totally 6 kinds of waveform display, available under both SDI and HDMI, to check the Luminance (Y), Blue-difference (Cb), Red-difference (Cr), Red (R), Green (G), Blue (B), and the Y, Cb, Cr can be simultaneously displayed, R, G, B can be simultaneously displayed, and each of the waveforms can be set to full scale display.

◆ **Vector scope**

The displayed vector scope pattern is available under both SDI and HDMI, represents saturation as distance from the center of the circle, and hue as the angle, in standard position, around it.

◆ **Histogram (R, G, B)**

The histogram is a bar graph that shows the distribution of luminance values in the picture. There're R, G, B histograms that individually displayed simultaneously, available under both SDI and HDMI.

◆ **16-ch audio meter**

Under HDSDI, it displays 16 channels audio bars, with mark, and under SDDSI or HDMI, it displays 2 channels audio bars with mark. The audio bar is green, and will turn yellow when audio exceeds -20dB, and turn red when exceeds -10dB.

◆ **SDI timecode**

Under SDI input, it can display the SMPTE timecode, which is used extensively for

synchronization, and for logging and identifying material in recorded media.

◆ **Peaking focus assist (red/blue switch)**

The Peaking focus assist function is to mark the sharpest edges of the image with red or blue color, for users to check if the subjects are focused.

◆ **Zebra stripes**

Zebra Stripes are used to check if the image is over exposed or not by showing black and white lines on the monitor. It is considered over exposed when luminance value exceeds 90%.

◆ **False color**

The false color is used to aid in the setting of camera exposure. Under false color mode, there's a false color key on the bottom of screen for reference. The over exposed subjects (above 101 IRE) on the monitor will display as RED, and the underexposed subjects will display as BLUE. For correct exposed subjects, it will display as green and pink.

◆ **Blue Only**

Under the Blue Only Mode, only the blue pixels are used to generate the image, because hue and saturation can be adjusted quicker and more accurately.

◆ **DSLR scale zoom in**

The Canon DSLR outputs the CMOS sensor ratio HDMI and this zoom in mode can make the effective image scale full screen on the monitor.

◆ **User definable function keys**

There are 3 function keys on the monitor front panel, that permit users to define shortcuts for the various functions.

◆ **User editable video title**

User can edit a video title for the current camera, and the title will display on the top of screen.

◆ **3-color TALLY light**

2 TALLY lights for each display unit, RS232 controlling port.

◆ **Image Flip**

Set image to rotate by 180°

2. Panel Instruction

Front view

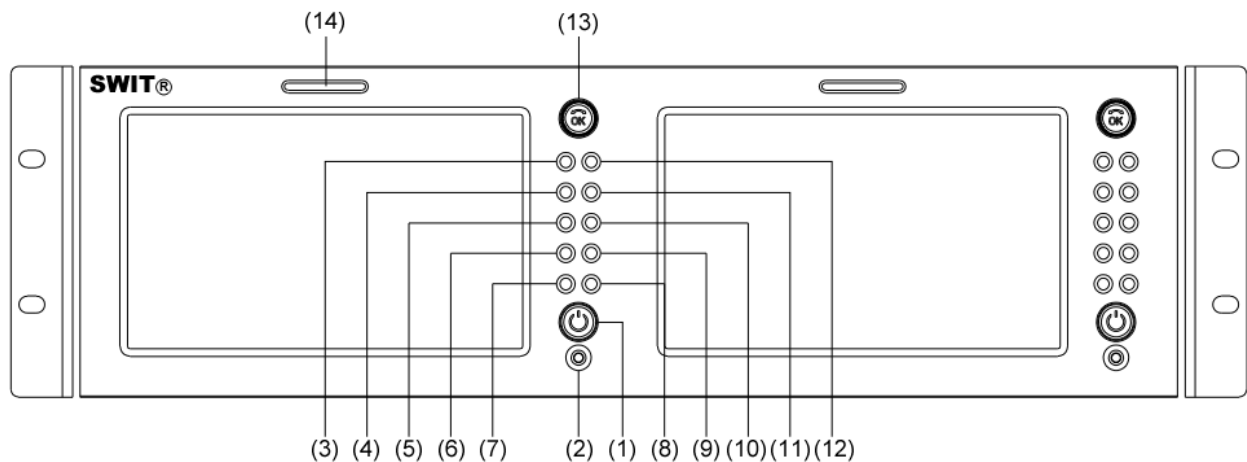

(1) **POWER:** Power on/off

Connect with power cable, press the “POWER” and the power indicator is turned on and the monitor will be switched on and get into normal working status. Press the “POWER” again, the indicator is turned off and monitor is switched off.

Disconnect with power cable if the monitor will not be used for a period of time.

(2) **PHONE:** 3.5mm Earphone socket, for SDI embedded audio, HDMI audio and analog audio monitoring

(3) **DISPLAY:** Display current settings

Press “Display” to display safety mark, title and the current input signal information

(4) **F.COLOR:** False color

Press “F.COLOR” once, it will display the current false color on/off status. Press “F.COLOR” again to switch on/off the false color mode.

(5) **FOCUS:** Peaking Focus Assist

Press “FOCUS” once, it will display the current peaking on/off status. Press “FOCUS” again to switch on RED line focus assist, switch on BLUE line focus assist, and switch off in turn.

(6) **F1:** User definable function key 1

(7) **SOURCE:** Input signal selection

Press “SOURCE” and revolve the “OK” to select the input video signal.

(8) **F2:** User definable function key 2

(9) **F3:** User definable function key 3

(10) **WAVEFORM:** Display waveform

Press “WAVEFORM” once, it will display the waveform menu as:
Revolve “OK” to select a waveform display mode and turn it on.
The selected waveform will display on the screen.

(11) **VECTOR:** Display vector scope

Press “VECTOR” to switched on/off the Vector scope

(12) **MENU:** Press to enter Menu

(13) **OK:** Select and Apply

Under menu system, revolve “OK” to adjust settings and press to apply; and out of menu system, directly revolve “OK” to adjust volume.

(14) **TALLY Light:** Red, Green and Yellow 3-color TALLY indicator

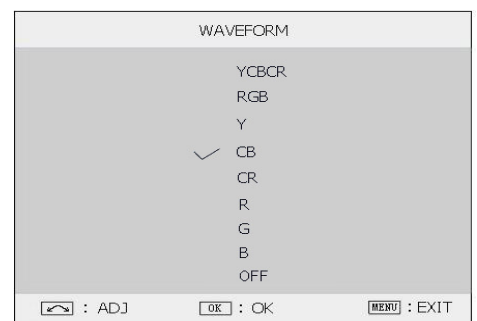

Rear view

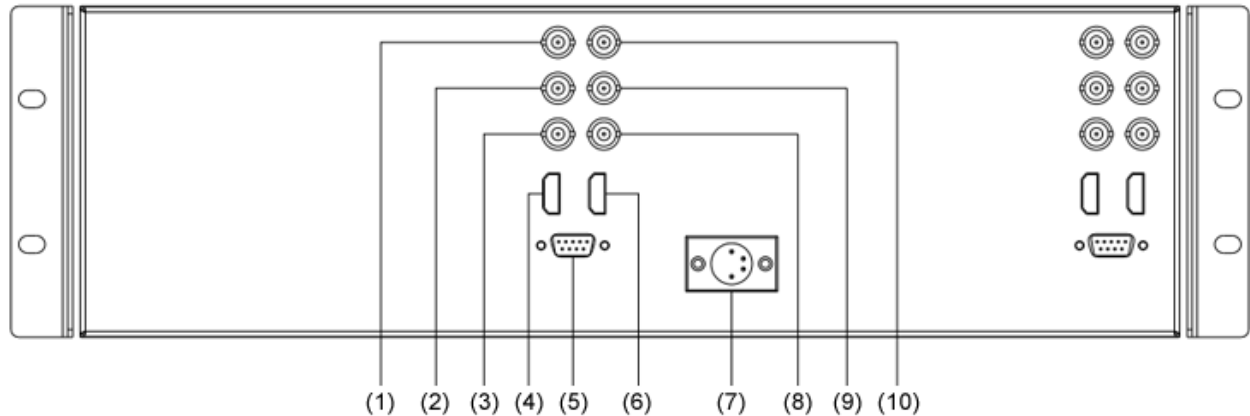

- (1) **SDI-OUT:** HDMI converted to SDI output (BNC connector)
- (2) **SDI-LOOP1:** HD/SD-SDI loop through output from SDI-IN1 (BNC connector)
- (3) **SDI-LOOP2:** HD/SD-SDI loop through output from SDI-IN2 (BNC connector)
- (4) **HDMI-IN:** HDMI input
- (5) **TALLY controlling port** (RS-232)
- (6) **HDMI-LOOP:** HDMI loop through output
- (7) **DC 12V IN:** Connect with DC12V 4-pin XLR power adapter. (Pin 1: Negative, Pin 4: Positive)
- (8) **SDI-IN2:** HD/SD-SDI input (BNC connector)
- (9) **SDI-IN1:** HD/SD-SDI input (BNC connector)
- (10) **CVBS-IN:** Composite video input (BNC connector)

Input formats

Input		Supported formats	
CVBS		PAL / NTSC	
HDMI		480i / 576i / 480P / 576P	
		1080i (60 / 59.94 / 50)	
		720p (60 / 59.94 / 50)	
SDI		1080p (60 / 59.94 / 50 / 30 / 29.97 / 25 / 24 / 23.98)	
		SMPTE-274M	1080i (60 / 59.94 / 50)
		SMPTE-296M	1080p (30 / 29.97 / 25 / 24 / 23.98)
		SMPTE-125M	720p (60 / 59.94 / 50)
ITU-R BT.656		480i (59.94)	
		576i (50)	

The 2 display units have the same input interfaces and input formats

3. Menu Operation

- (1) Press "MENU" and it will display menu system
- (2) Revolve "OK" to select an item. The selected item will be highlighted display.
- (3) Press "OK" to enter the selected item.
- (4) Under menu system, press "MENU" to back to previous menu.

*The menu will automatically save and quit if it remains idle.

3.1 PICTURE submenu

The PICTURE submenu includes:

- (1) **CONTRAST:** 0-100 value adjustment
- (2) **BRIGHTNESS:** 0-100 value adjustment
- (3) **HUE:** 0-100 value adjustment
(Only available under CVBS NTSC input)
- (4) **SATURATION:** 0-100 value adjustment
- (5) **SHARPNESS:** 0-100 value adjustment

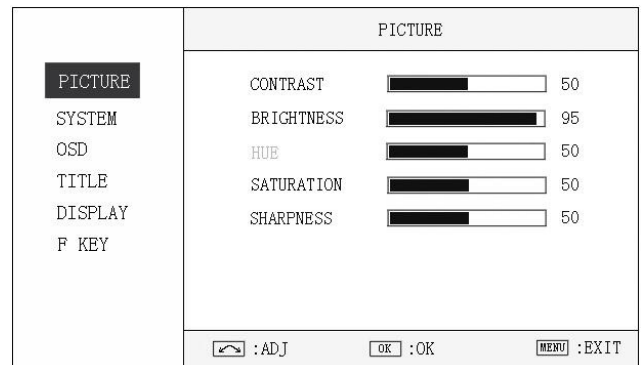

3.2 SYSTEM submenu

The SYSTEM submenu includes:

- (1) **RATIO:** Aspect ratio "16:9" / "4:3" selection
- (2) **SCAN:** "UNDERSCAN" / "OVERSCAN" selection
- (3) **ZOOM:** "OFF", "ZOOM1" and "ZOOM2" selection
ZOOM1: Canon DSLR scale zoom-in
ZOOM2: Pixel to Pixel zoom-in
- (4) **MARKER:** Select and set the safe area scale from 80%, 85%, 90% and 95%.
- (5) **FLIP:** Select "ON" to flip the picture by 180°.
- (6) **RESET:** Select "YES" to recover all to factory setting.

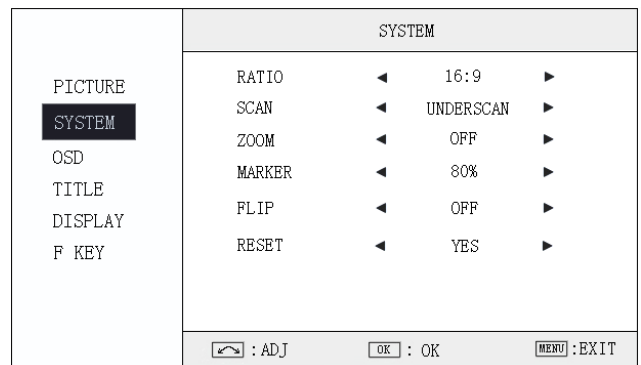

3.3 OSD submenu

The OSD submenu includes:

- (1) **LANGUAGE:** Menu language selection
- (2) **H-POSITION:** Menu horizontal position (0-100) adjustment, real-time preview and default value: 50.
- (3) **V-POSITION:** Menu vertical position (0-100) adjustment, real-time preview and default value: 50.
- (4) **DURATION:** Menu timeout setting (5-60)
Set a time (in seconds) in which the menu will automatically quit if remains idle. Default: 15.

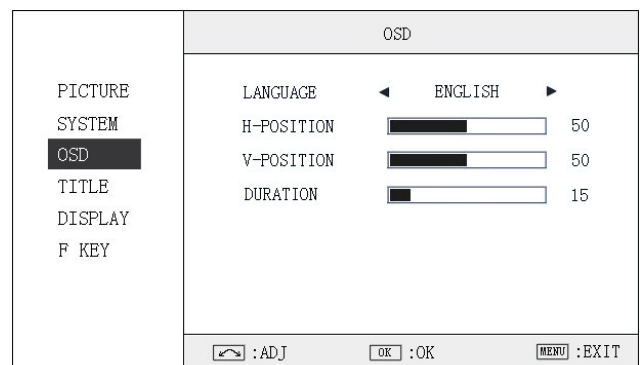

3.4 TITLE submenu

Revolve "OK" button to select the letters, and press "OK" to input. Select SPACE to input space and DEL to delete the left letter. Max 10 letters are supported.

After setting, press "MENU", the system will save data to current user and quit menu. The menu will automatically save and quit if it remains idle.

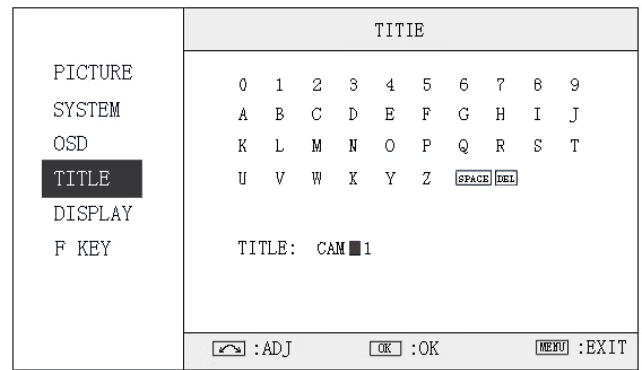

3.5 DISPLAY submenu

The DISPLAY submenu is to select the items to be displayed on screen when 'DISPLAY' button is pressed.

Revolve "OK" to turn on/off the items:

- (1) **INFO:** Including Input format, aspect ratio, underscan/overscan, zoom status
- (2) **MARKER:** Safe area
- (3) **TITLE:** User edited title
- (4) **MARKER4:3:** The 4:3 scale mark on 16:9 image. (Only available under HD input)

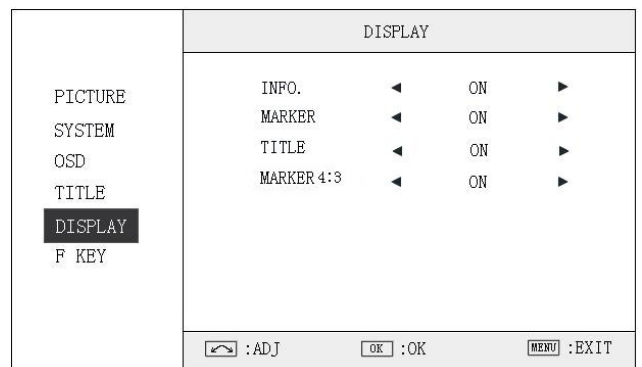

3.6 F KEY submenu

The F KEY Settings Submenu is to define Function Key F1, F2 and F3. The available function items are:

- 01- RATIO:** Aspect ratio 16:9 / 4:3 switch
- 02- SCAN:** Underscan / Overscan switch
- 03- ZOOM:** Picture Zoom-in
- 04- B/W:** Color / Black & white switch
- 05- BLUE ONLY:** Blue only mode switch on/off
- 06- ZEBRA:** Zebra over exposure switch on/off
- 07- VECTOR:** Vector scope switch on/off
- 08- PATTERN:** Internal colorbar switch on/off
- 09- RGB HIST:** R, G, B Histogram switch on/off
- 10- TIMECODE:** SDI timecode display switch on/off
- 11- F.COLOR:** False color mode switch on/off
- 12- AUDIO BAR:** Audio meter display switch on/off
- 13- FOCUS:** Peaking focus assist switch on/off,
- 14- FLIP:** Image flip

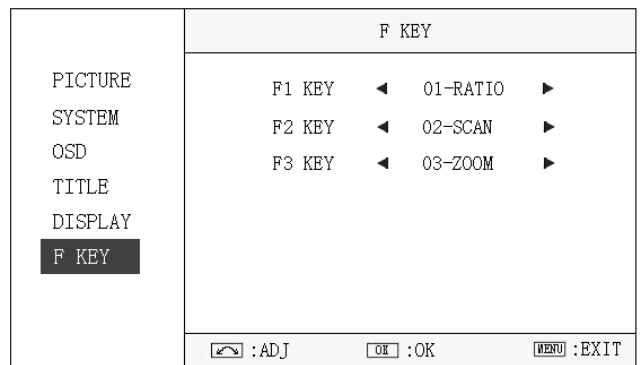

4. TALLY Light Operation

There are front TALLY lights on each of the display units, which can display RED, GREEN and YELLOW signals. The TALLY light controlling port is the RS232 socket at the rear panel, and terminal description is as follows:

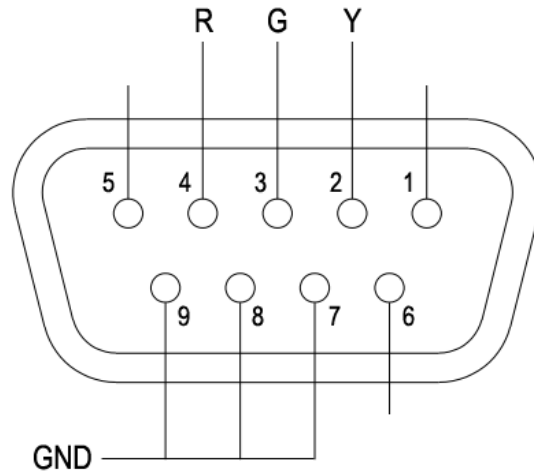

Terminal	1	2	3	4	5	6	7	8	9
Description		Y	G	R			GND	GND	GND

The RED light is on when connecting the terminal “R” with “GND”, and goes out when disconnecting.

The GREEN light is on when connecting the terminal “G” with “GND”, and goes out when disconnecting.

The YELLOW light is on when connecting the terminal “Y” with “GND”, and goes out when disconnecting.

5. Specifications

LCD Performance		
Size	7.0 inches ×2	
Display area	153.6×90mm	
Resolution	1024×RGB×600	
Aspect ratio	16:9/4:3	
Brightness	400cd/m ²	
Contrast	900:1	
Color	16.77 million colors	
Viewing angle	Horizontal: 160° Vertical: 160°	
Video Format		
CVBS	NTSC / PAL	
SDI	SMPTE-274M	1080i (60 / 59.94 / 50)
		1080p (30 / 29.97 / 25 / 24 / 23.98)
	SMPTE-296M	720p (60 / 59.94 / 50)
	SMPTE-125M	480i (59.94)
	ITU-R BT.656	576i (50)
HDMI		480I / 576I / 480P / 576P
		1080i (60 / 59.94 / 50)
		720p (60 / 59.94 / 50)
		1080p (60 / 59.94 / 50 / 30 / 29.97 / 25 / 24 / 23.98)
General		
Working voltage	DC 12V	
Power consumption	≤24W	
Working temperature	0℃~+40℃	
Working humidity	10%~90%	
Storage temperature	-15℃~+60℃	
Storage humidity	10%~90%	
Dimensions	487×130×80mm, Standard 19" rack, 3U height.	
Net weight (main body)	2.3kg	

6. Packing List

1. Monitor	×1
2. User Manual	×1
3. Power adaptor	×1
4. Power cable	×1
5. LCD protection film	×2

SWIT®