

4

3

2

1

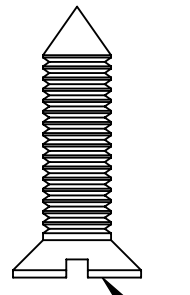
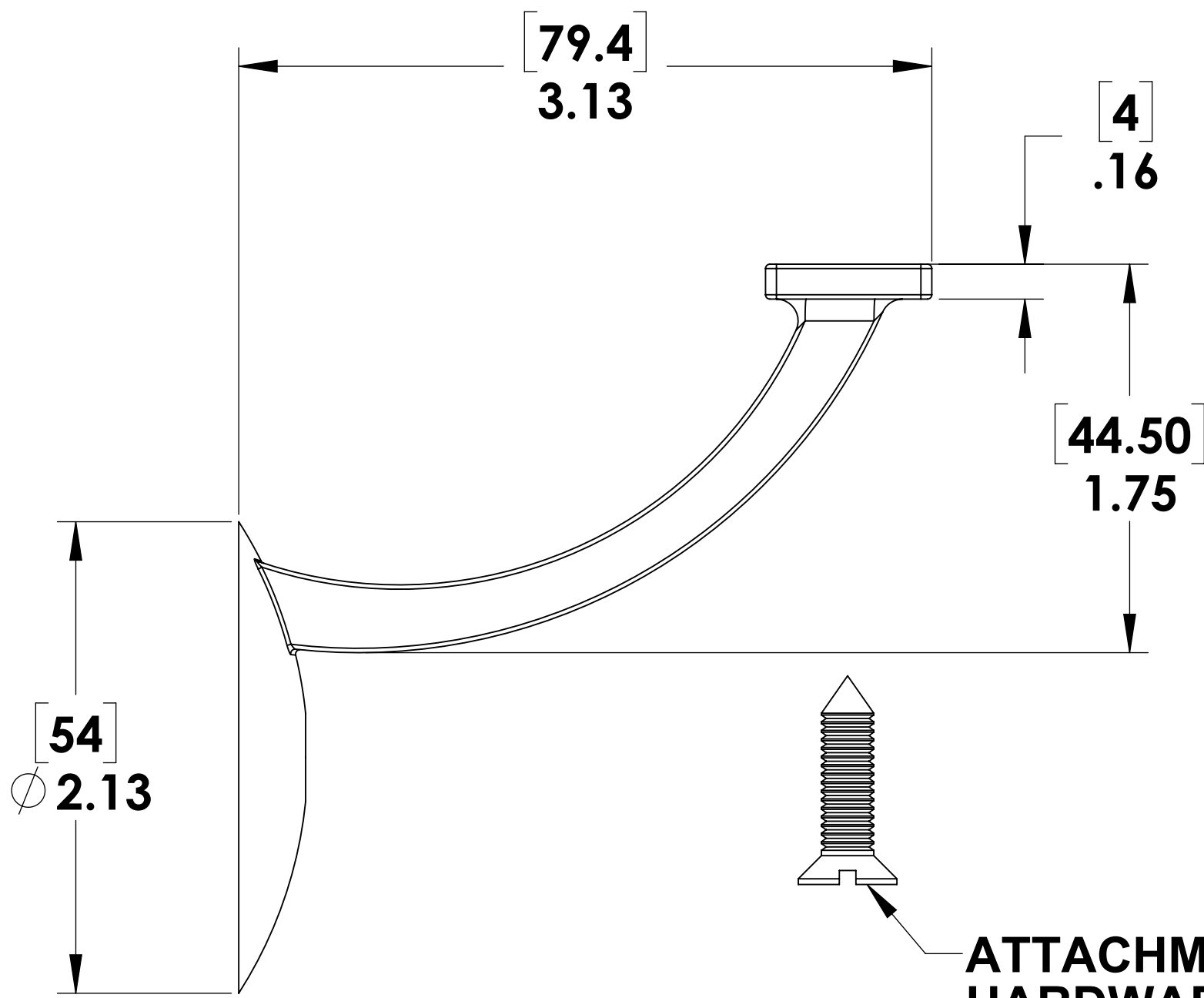

ATTACHMENT
HARDWARE
WILL VARY

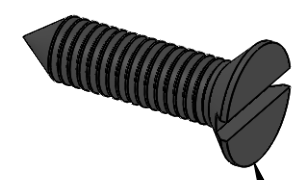

ATTACHMENT
HARDWARE
WILL VARY

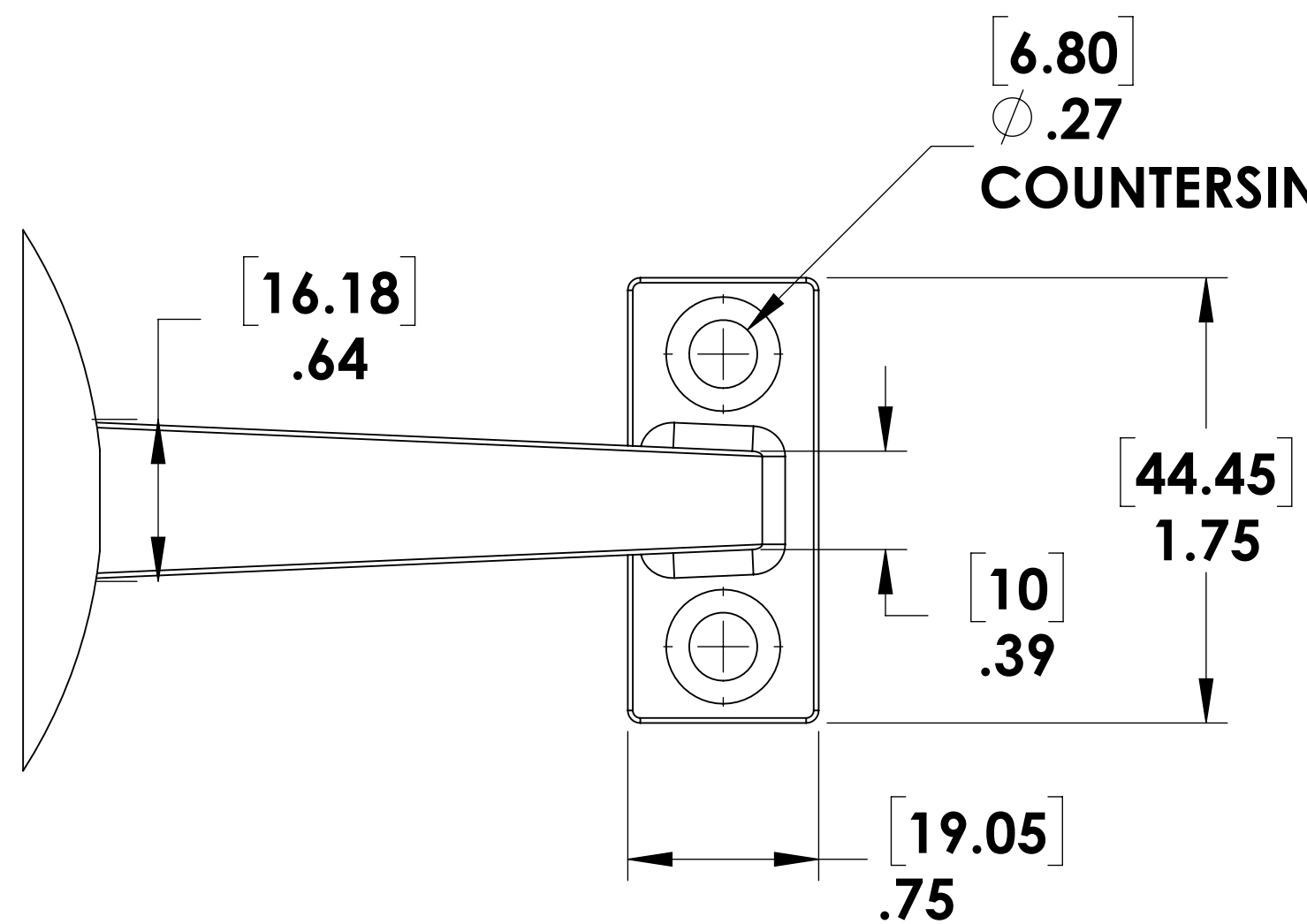

COUNTERSINK HOLE



PROPRIETARY AND CONFIDENTIAL
THE INFORMATION CONTAINED IN THIS DRAWING IS THE SOLE PROPERTY OF STAINLESS CABLE AND RAILING. ANY REPRODUCTION IN PART OR AS A WHOLE WITHOUT THE WRITTEN PERMISSION OF STAINLESS CABLE AND RAILING IS PROHIBITED.

NOTES: UNLESS OTHERWISE SPECIFIED		NAME	DATE
1. DUAL DIMENSIONS SHOWN - INCHES (MM).	DIMENSIONS ARE IN INCHES FRACTIONAL	DRAWN	SCR
2. MACHINED SURFACES TO BE 63μIN MAX.	ANGULAR: MACH ±	ENG APPR.	10/23/17
3. PART TO BE FREE OF BURRS AND SHARP EDGES.	TWO PLACE DECIMAL ±	MFG APPR.	
4. ALL MATERIAL TO BE CLEAN, DEGREASED AND FREE OF ALL IMPURITIES.	THREE PLACE DECIMAL ±	COMMENTS:	
5. ANY CHANGE MUST BE AUTHORIZED BY AN SC&R ENGINEER.	MATERIAL		
	316 SS		
	FINISH		

SIZE	DWG. NO.	REV
C	730215	01

TITLE:		
POST-TO-POST HANDRAIL BRACKET		
SCALE: 3:2	WEIGHT:	SHEET 1 OF 1

4

3

2

1