



Standard Operations (Detailed Programming Instructions)

SmartPhone VI

Keypad Programming

Step 1: Begin Program Mode

- a. Press **Enter**

Step 2: Program Emergency Numbers

- a. Press **1, Enter**, (phone number), **Stop**.

To program numbers 2-5, repeat Step 2 a.

Example: To program emergency number 2, press **2, Enter**, (phone number), **Stop**.

Note: If installed on a ring down line (no dial tone) do not program phone number, press the following: **1, 9, Enter, 2** (automatically sets the timer for 3 minutes).

Step 3: Program Location Message

- a. To turn on message press **1, 3, Enter, 2**
b. Press **6, Record**, wait for the "beep", then speak message, **Stop**. To replay message, press **6, Play/Pause**.
c. Program frequency of message, press **1, 3, Enter, __**
0 = No message
2 = Plays message (2) times (default)
3 = Plays message until receiving party presses *

Note: Called party can replay message by pressing *,*.

Step 4: Exit Program Mode

- a. Press **Stop** for 3 seconds

Remote Programming

(Landline Phone Recommended)

Step 1: Begin Program Mode

- a. Call into phone
b. After first simulated ring, press **#, #**
c. Key in security code (default is **1111**)

Step 2: Program Emergency Numbers

- a. Press **1, *, (phone number), *, #**.
To program numbers 2-5, repeat Step 2 a.

Example: To program emergency number 2, Press **2, *, (phone number), *, #**. For a pause, press **#, ***.

Note: If installed on a ring down line (no dial tone) do not program a phone number, press the following: **1, 9, *, 2** (automatically sets the timer for 3 minutes).

Step 3: Program Location Message

- a. To turn on message, press **1, 3, *, 2**
b. Press **6, ***, wait for the "beep", then speak message, **#**. To replay message, press **6, #**.
c. Program frequency of message, press **1, 3, *, __**
0 = No message
2 = Plays message (2) times (default)
3 = Plays message until receiving party presses *

Note: Called party can replay message by pressing *,*.

Step 4: Exit Program Mode

- a. Press ***, #, 0** (you will hear beep beep) ***, #**

Optional Programming Features

Program Talk Timer

(Default is 5 minutes, ring down is 3 minutes)

Keypad:

Press **8, Enter**, (3 digit number in minutes)

Remote:

Press **8, *, (3 digit number in minutes)**

Example: 2 minutes = 002

Note: After talk time expires, phone will prompt called party to extend call for 3 minutes.

Phone Line Check: (Default is 10 minutes)

Keypad: Press **3, 4, Enter**, (4 digit number in HH:MM)

To turn off, press **23, Enter, 3, 23, Enter, 7284, 11, Enter, 2**

Remote: Press **3, 4, *, (4 digit number in HH:MM)**

To turn off, press **23, *, 3, 23, *, 7284, 11, *, 2**

Example: 20 minutes = 0020, 10 hours = 1000

Example: 20 minutes = 0020, 10 hours = 1000

Consolidator Feature: (Allows up to (10) SmartPhones on a single telephone line and toggle between them from an outside call)

Step 1: Begin Program Mode

- a. Press **Enter**

Step 2: Program ID Numbers for Phones 1-5

- a. Press **7, Enter**
b. Press ***, 1-5** for corresponding elevator 1-5

Step 3: Program ID Numbers for Phones 6-10

- a. Press **7, Enter**
b. Press **#, 1-5** for corresponding elevator 6-10

Step 4: Exit Program Mode

- a. Press **Stop** for 3 seconds

Step 5: Confirm Consolidator Operation

- a. Dial phone number connected to SmartPhones: All phones will answer
b. To select individual phone:
Press ***1** (Phone #1) Press **#1** (Phone #6)
Press ***2** (Phone #2) Press **#2** (Phone #7)
Press ***3** (Phone #3) Press **#3** (Phone #8)
Press ***4** (Phone #4) Press **#4** (Phone #9)
Press ***5** (Phone #5) Press **#5** (Phone #10)
Press ***0** (All Phones)



Wiring Diagrams: 24vac/dc Models

Direct 24vac/dc Powered

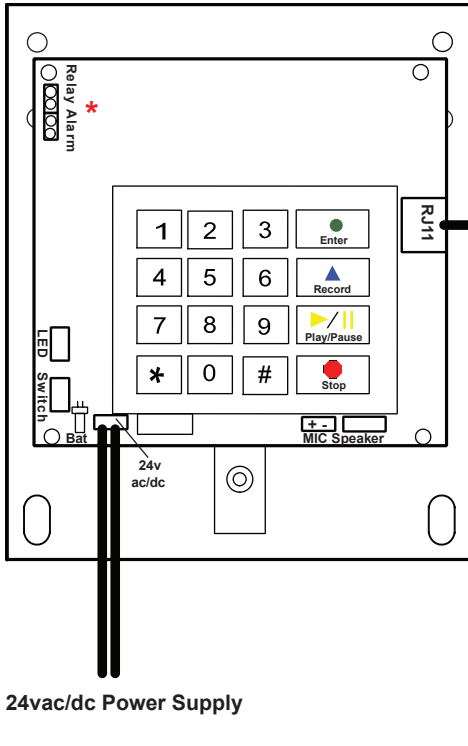

Note:
If Elevator Communications Failure is required, connect to our Alarm Relay *

To Phone Line:
Requires a twisted shielded pair. When used with SmartRescue, requires two twisted shielded pairs.

To 24vac/dc Power Supply

120vac to 24vac/dc Powered

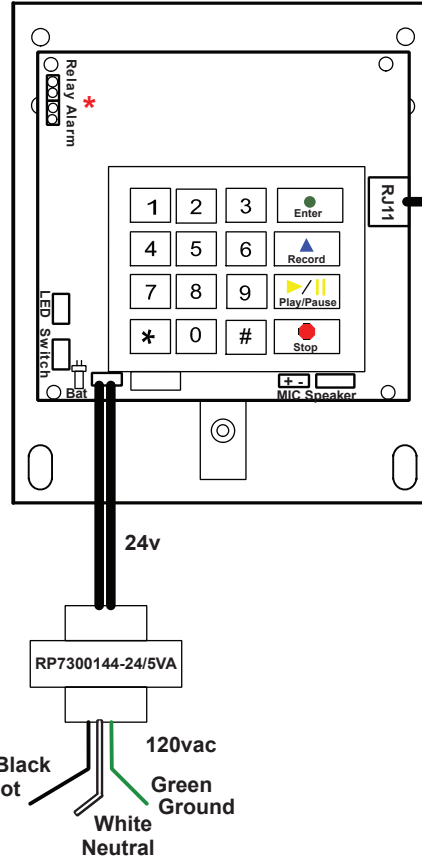

Note:
If Elevator Communications Failure is required, connect to our Alarm Relay *

To Phone Line:
Requires a twisted shielded pair. When used with SmartRescue, requires two twisted shielded pairs.

Annunciator Interface, Auxiliary Relay & 24v LED Board

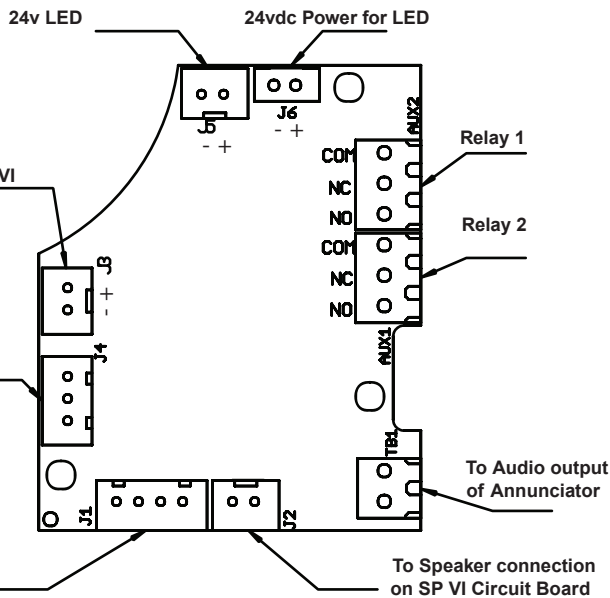

1. Connect your annunciator's audio output to the TB1 connection on this board.
2. When utilizing this board to drive a 24v LED, you must apply power to the wire leads at the J6 connection. You may tap into a direct 24vdc supply that has battery backup. Connect the wire leads at the J5 connection to your LED.
3. If you are not utilizing this board to drive a 24v LED, you need to disconnect the LED harness from the SmartPhone board, disconnect the LED harness from this board, connect it to the SmartPhone board, and then wire to your standard LED.
4. If you want to activate Relay 2 in unison with Alarm Relay on SmartPhone board, follow these programming steps (default activates upon call out):
 - a. Press **ENTER**
 - b. Press **3, 0, ENTER, 4**
 - c. Press **STOP** for 3 seconds



Initial Set-Up:

1. Diagnostic Test: Press **Enter, 2, 6, Play/Pause** phone will play back (5) Beeps (1st Beep=External Power Supply; 2nd Beep=LED; 3rd Beep=Microphone; 4th Beep=Speaker; 5th Beep=Backup Battery). If any item fails during test you will hear a Blat not a Beep. If you hear a Blat, contact RATH® Technical Support.

Note: If you receive a Blat for the LED, check the LED operation to be sure it is not working before contacting RATH® Technical Support.

2. Connect to standard RJ11 phone jack. If splicing connection, only hook up Red and Green Wires from the phone cable. If connecting to a SmartRescue unit, you must connect all four wires (check for 24vdc or 48vdc supply at the splice).

Troubleshooting:

1. If the phone dials only one digit and hangs up, there is another Auto-Dialer on the line. You need to re-wire the system so that the RATH® unit is either in parallel or ahead of it.
2. If the phone dials a couple of digits and gets a busy signal, the unit is installed on a switchboard line and needs to be programmed to dial the appropriate access code to get an outside line (usually an 8 or 9).
3. If the phone does not respond, make sure the green LED (D1) on the circuit board is lit. If not, check to be sure the power is properly connected.
4. If the phone is making phantom calls, it is installed on a Ring Down Line. You must turn off the "Telephone Line Check" feature (see Optional Programming Instructions).

Wiring Diagrams: 12vac/dc Models:

