

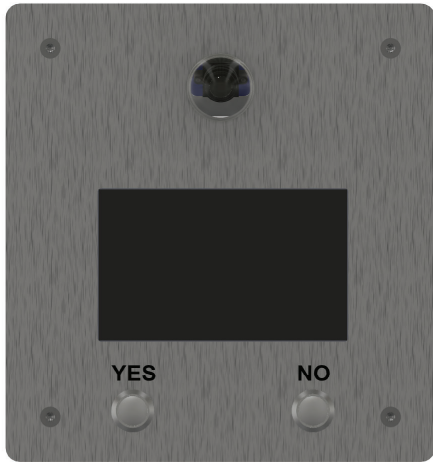

SmartView System
Part #: 2100-SVFCOMP

Features:

- **Overall Dimensions:** 8" H x 9.25" W x 2" D
- **Operating Temperature:** 32°F to 158°F (0°C to 70°C)
- **Power Requirement:** 12v or 24v power supply or PoE
- Flush mount
- Back box included
- All-in-one mounting frame includes SmartView Controller Board, Display, Camera, and Buttons
- Compatible with the SmartView Software
- The SmartView Controller Board features a uniquely assigned ID address for easy software setup
- Requires CAT5 or better Ethernet connection or connection to a 2-wire extender
- Requires power from the elevator or remotely in the machine or electrical room
- **Data Usage:** 4.4 mb/minute in active state
0 in idle state (pings every 24 hours)
- **Current Draws**
 - Board:** 12v = 1A, 24v = 0.5A
 - Camera:** 5v = 0.12A (powered by board)
 - Display:** 5v = 0.59A (powered by board)
 - Total:** 12v = 1.46A, 24v = 0.73A



Front View



Angled View

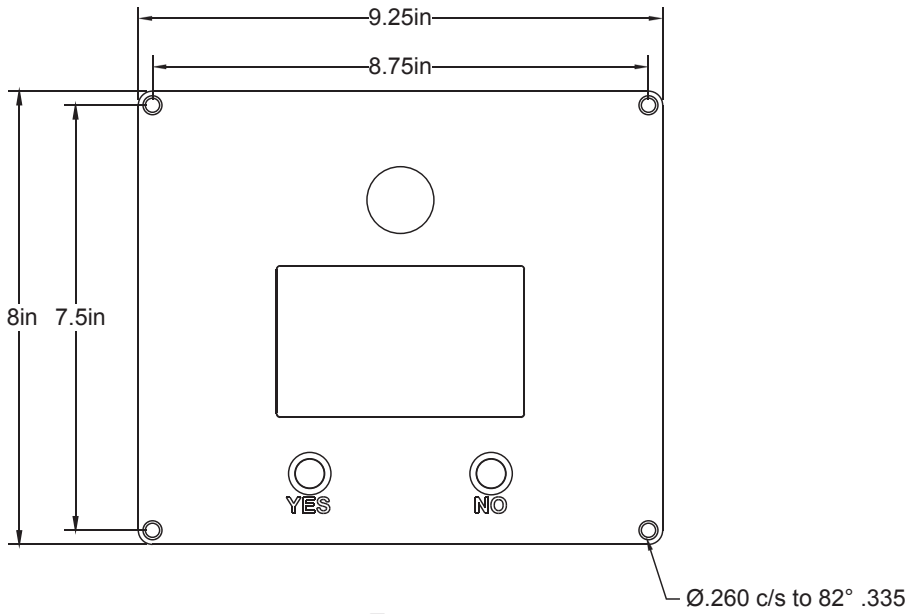

Front

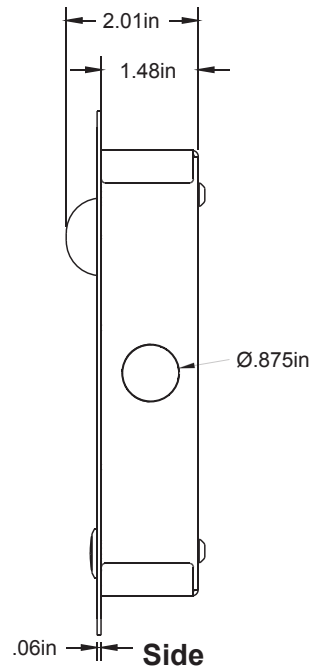

Side

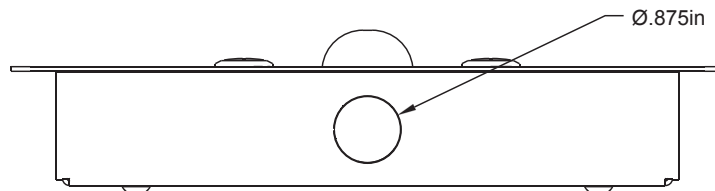

Top