

2019 ULTIMATE BAGGER SPECIFICATION SHEET

DIMENSIONS

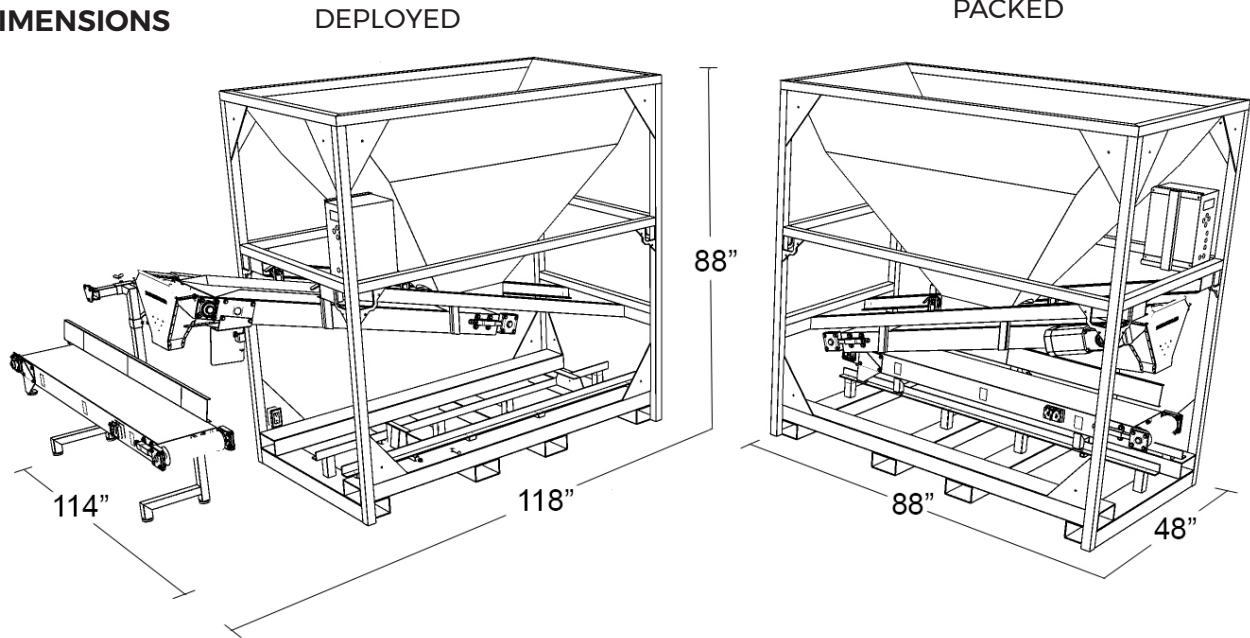

SPECIFICATION	STOCK	UPGRADE (OPTIONAL)
WEIGHT LB (KG)	1896 LB (933 KG)	SELF PWR - +TBD LB STANLS STL - +TBD LB
PART NUMBER	TE12ST	STAINLESS STEEL/EXTERNAL POWER: TE12SE STAINLESS STEEL/SELF POWER: TE12SP STANDARD STEEL/SELF POWER: TE12RP
CONSTRUCTION	SHEET METAL: 10 GA STEEL FRAME VERT: 2 X 3/16" SQR TUBE FRAME CROSS: 2 X 1/8" SQR TUBE FRAME BASE: 7 X 4" 4-WAY FORK TUBE RETRACTABLE FEEDER BELT COLLAPSIBLE BAG CLOSING BELT	SHEET METAL: 10 GA STAINLESS STEEL
MOTOR	FEEDER BELT: 1/2 HP HYPOID DRIVE ELECTRIC GEAR MOTOR BAG CLOSING BELT: 1/5 HP HYPOID ELECTRIC GEAR MOTOR	ON-BOARD GENERATOR: TBD ON-BOARD AIR COMPRESSOR: TBD
POWER/AIR REQUIREMENTS	POWER: 120V 15A SINGLE OUTLET AIR: 4 CFM @ 120 PSI (MINIMUM)	POWER: 240V 50/60 HZ
CONTROLS	CYCLE ACTIVATION: ADJUSTABLE PROXIMITY TOUCH SWITCH LOGIC: ON BOARD MICROCONTROLLER WITH 10 BUTTON INTERFACE AND LCD. ADJUSTABLE CONTROLS: <ul style="list-style-type: none"> · BAG FILL LEVEL · CLAMP HOLD TIME (TRICKLE DELAY) · AGITATOR SELECTION & RUN TIME · PALLET COUNTER W/ALARM 	
VIBRATION	DUAL 5000 LB FORCE AGITATORS WITH ADJUSTABLE FORCE AND DYNAMIC RUN-TIME CONTROL	