

2

1

BILL OF MATERIAL TABLE

ITEM NO.	PART NUMBER	DESCRIPTION	QTY.
1	STD-SW-11	1/2" DOMED CAP	1
2	STD-SW-12	1/2" SCREW BASE	1
3	STD-SW-13	1/2" SLEEVE	1

(Ø 1.170)

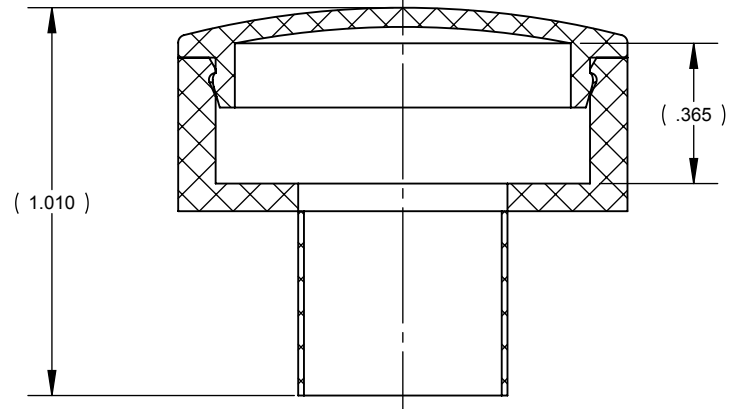
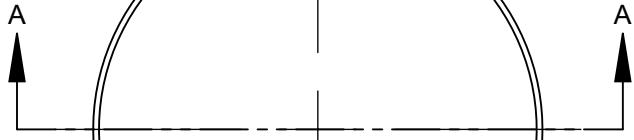

SECTION A-A

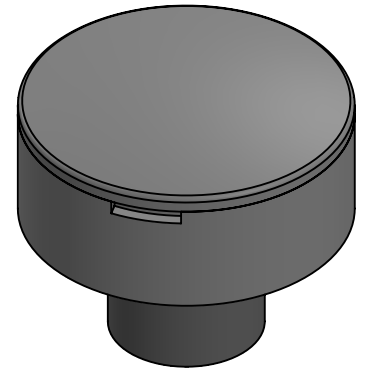
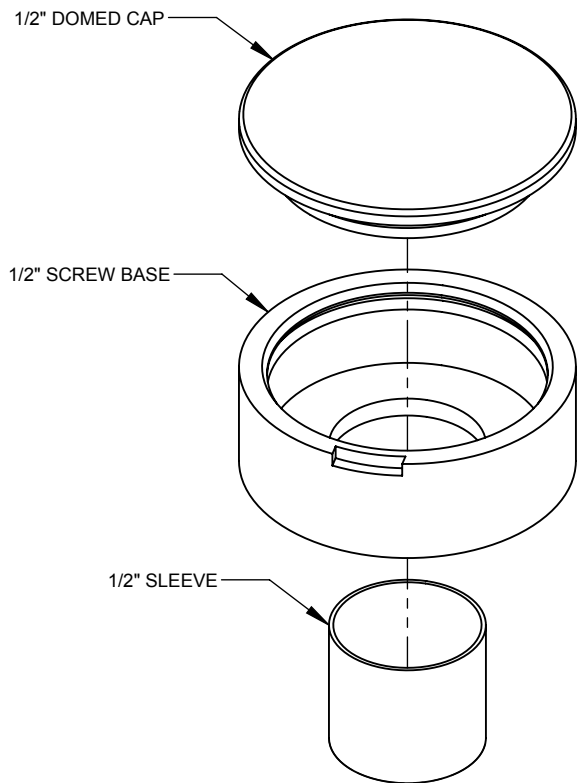

B

B

A

A

eGlass Element™
eGlass Solid™
eGlass Vision™
eGlass Picket™

PROPRIETARY AND CONFIDENTIAL

THE INFORMATION CONTAINED IN THIS DRAWING IS THE SOLE PROPERTY OF EGLASS LLC. ANY REPRODUCTION IN PART OR AS A WHOLE WITHOUT THE WRITTEN PERMISSION OF EGLASS LLC IS PROHIBITED.

NOTES: UNLESS OTHERWISE SPECIFIED		NAME	DATE
1. DIMENSIONS SHOWN - INCHES [MM]. 2. MACHINED SURFACES TO BE 63µIN MAX. 3. PART TO BE FREE OF BURRS AND SHARP EDGES. 4. ALL MATERIAL TO BE CLEAN, DEGREASED AND FREE OF ALL IMPURITIES. 5. ANY CHANGE MUST BE AUTHORIZED BY AN EGLASS ENGINEER.	DIMENSIONS ARE IN INCHES	DRAWN	V.P.
	FRACTIONAL ±	ENG APPR.	
	ANGULAR: MACH ±	MFG APPR.	
	TWO PLACE DECIMAL ±		
	THREE PLACE DECIMAL ±	COMMENTS:	
MATERIAL	ASA	PURCHASER HAS THE FULL RESPONSIBILITY TO COMPLY WITH LOCAL, NATIONAL AND INTERNATIONAL BUILDING CODES. PURCHASER SHALL COMPLY IN ALL RESPECTS WITH ALL APPLICABLE LEGAL REQUIREMENTS GOVERNING THE DUTIES, OBLIGATIONS, AND BUSINESS PRACTICES OF THEIR LOCALITIES AND SHALL OBTAIN ANY PERMITS OR LICENSES NECESSARY FOR THEIR OPERATIONS.	
FINISH			
DO NOT SCALE DRAWING			

TITLE: 1/2" SCREW COVER		
SIZE	DWG. NO.	REV
A	STD-SW-10	1
SCALE: 2:1	WEIGHT:	SHEET 1 OF 1

2

1