

# Over Armour Offroad

2515 Bypass Rd. Flemingsburg, KY 41041  
606-845-7439

**Instructions for Installation and Care of**  
**2014 John Deere Gator XUV 825i**  
**Full Cab With Poly Windshield**  
JD-XUV14-FC04

**Notice: Do not smoke inside the cab or expose the enclosure to direct flames. Cab is Flammable.**

1. Be sure to read these instructions thoroughly before opening and installing the 2014 John Deere 825i Full Cab with polycarbonate windshield. The installation is best done when the temperature is 70 degrees F. or warmer. The temperature affects the adhesive Velcro, if conditions prevent installing in warmer weather it helps to store the adhesive Velcro at room temperature prior to installation.
2. Carefully open the carton and remove the enclosure on a large flat surface that is clean and free of dirt.
3. Check over the parts included in the carton with the parts list shown below:

Adhesive Velcro Hook Strips:	14 each-----3”
“ “ “ “	4 each-----6”
“ “ “ “	4 each-----8”
“ “ “ “	2 each-----10”
“ “ “ “	2 each-----12”
“ “ “ “	2 each-----15”
“ “ “ “	2 each-----17”
“ “ “ “	1 each-----26”
“ “ “ “	2 each-----42”
“ “ “ “	1 each-----53”
Webbing strap w/ Grommet	2 each
Webbing strap with Velcro	4 each
Cab Enclosure	3 panels

The cab will be put together using the following parts and in this order.

- 1 Soft Doors
- 2 Rear Window
- 3 Aero-Vent Poly Windshield ( **Use Instructions provided with Windshield** )
- 4 Soft Top

## **SOFT DOORS**

4. Begin by installing the soft doors. If possible, have someone else hold the door in place and mark the location of each Velcro strip sewn along the edge of the door. Now take the supplied 3” adhesive Velcro strips and wrap them around the roll cage at the marked

locations. Now put the door back onto the vehicle and wrap the double-sided Velcro around the adhesive Velcro as shown in the photos on the next page.



5. The diagrams below show how the double-sided straps and the 3" adhesive Velcro works.

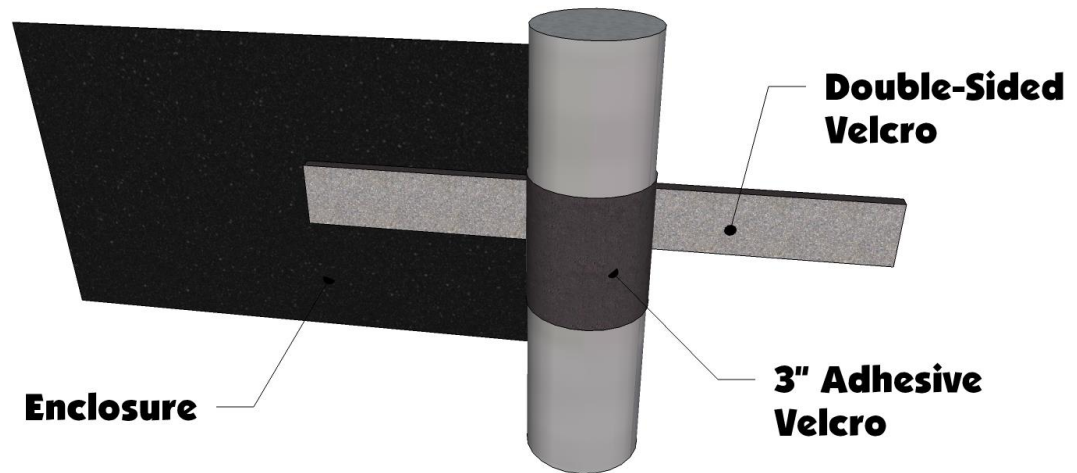

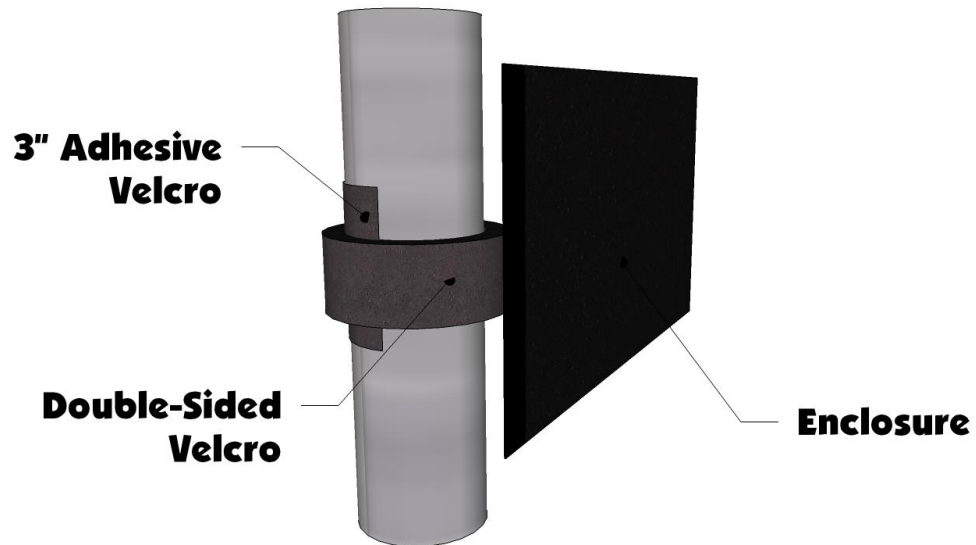

- Now that the doors are in place and all the double-sided strips are attached to the frame you can now attach the remaining pieces of adhesive Velcro to match up with the Velcro tabs or strips sewn to the front door. Going down the REAR of the doors there is one at the top that will Velcro onto the flat metal towards the rear of the vehicle. You will use an 8" adhesive Velcro strip here. Below the flat part you will take the 34" adhesive strip and run it down the bar facing the rear of the vehicle. The pictures below show how these Velcro strips should look.



- Now it's time to work on the bottom of the door. The front part has two strips of Velcro that goes on the front fender. The outer portion of the door has Velcro sewn to the bottom of it and will attach flat to the top of the fender. The bottom front section of the door has a strip of Velcro that attaches to the fender facing the rear of the vehicle. Photos below shows where the Velcro strips should be.



8. Lastly place an adhesive Velcro strip along the side of the floor as shown below.

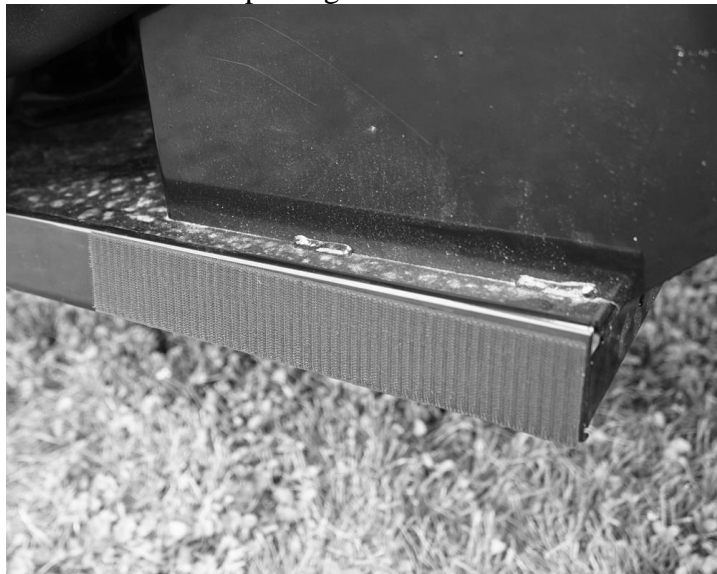



### **REAR WINDOW**

9. Start the Rear Window installation by attaching the 53” adhesive Velcro along the bottom of the vehicle across the back as shown in the photo below.



10. Next attach a piece of 26” adhesive Velcro across the top bar, it should be placed on the top slightly angled towards the front of the vehicle. See Photo below.



11. The sides of the rear window will attach to the double-sided Velcro tabs that hold the rear of the doors in place.

12. This concludes your installation. If you have any questions please call Mammoth Designs. Thank You

### **13. Top Panel**

- a.** If you have a Lexan windshield already installed on your Gator you can do one of two things. You may use the straps with Velcro sewn to one end and wrap the roll cage under the windshield with the 6" adhesive Velcro strips. Then wrap the double sided Velcro sewn to the end of the strap around the adhesive Velcro. If you choose you may also drill a 5/16" hole in the windshield and bolt the strap with the grommet directly to the windshield. The bolt should be installed from the inside out with a washer then strap, another washer and a locknut. Tighten all the way down and then loosen the locknut ½ a turn to free the strap to allow it to swing around to any position.
- b.** Now place the top over the entire vehicle, the front of the top is identified by the sides not being as steeply curved, and begin by lacing the front straps through the ladder lock buckles sewn to the front corners of the top.
- c.** Now take two of the straps that are sewn to the double-sided Velcro and wrap then around the rear bar of the roll cage halfway between the bottom and the first bend up the bar. The strap should be on the outside of the bars.
- d.** Now run those straps up and through the ladder lock buckles sewn to the rear of the top.
- e.** You now need to tighten and loosen the strap of the top so that it is centered correctly and should cover the holes across the top of the windshield.
- f.** If you were installing the Top by itself you would use the two remaining straps with double-sided Velcro to attach the front. You may need to cut the straps once fitted, do not cut off too much as you have nothing to hold on to and pull it tight the next time you go to install it. It is recommended to leave about 6-8" hanging from the buckles.

#### Cleaning and Storage Recommendations:

1. Before removing the Mammoth Cab for storage, make sure it is very clean in order to prevent scratching of the window panels. Clean with a soft rag or sponge using a mild liquid detergent soap and warm water solution. Never rub the windows with a dry cloth or rag! Let the Cab dry thoroughly before attempting to roll for storage.
2. It is important that the Cab be rolled up for storage rather than folding. Folding will cause damage to the windows!!! Carefully roll up the Cab similar to the way it was when it was packed at the factory. On a large, clean and flat surface, fold the doors over the rear panel first, then, interleave the top and windshield on top of the doors. Begin rolling the Cab into a roll approximately 8 inches in diameter. Put the rolled Cab back into the carton for storage at a normal room temperature. It is best not to expose the Cab to either extreme hot or cold temperatures when storing.

3. A special cleaner conditioner is available from Mammoth Designs that will greatly increase the service life of the Cab Enclosure. In addition, if additional hook and loop sets are needed, they can also be ordered.

## **Return Policy**

If for any reason you choose to return this product it must be returned within **30 days from date item is received**. You **MUST** package the product exactly **as it was originally packaged from the factory to get a full refund for the product!**

The vinyl windows should never be folded when packaging in the box or for storage purposes. Lay all the windows on top of each other with the canvas folded in between and the paper (if available) on both sides of the windows.

**All returned products will be inspected upon arrival at the production facility and must be in unused, factory new condition to receive refund - a 25% restocking fee will apply.**

If ordered from Over Armour Offroad please call at 606-845-7439 to gain a return authorization number, use our preferred shipping carrier (UPS) to return the item (unless the item is defective, you are responsible for paying the shipping to return the item.) **Any returns submitted to Over**

**Armour Offroad without a return authorization number will be charged a 20% restocking fee. If ordered from one of Over Armour Offroads many distributors', you must first call them and see what their return policy is. Once your item reaches our production facility, our customer satisfaction team will inspect your item to ensure unused, factory new condition. NOTE: All windshields must be returned with the original protective film intact and not removed. Do NOT REMOVE if you have any intentions of returning the item. Refund/ replacement of a windshield will only be processed on items with original protective film or if the windshield is defective.**

Items must be properly packaged in the original shipping carton to protect them during transit and ensure your returned item arrives back factory fresh, and in new resalable condition (**any returned items that have been used, altered or damaged in any way will not be subject for a refund.**) All contents including instruction manuals, accessories, hardware, Velcro, etc. must be included in your return shipment. Only items in OEM factory new condition will be approved. Once returned items are received, credit will be issued to the original credit card/ payment method used for the purchase. Outbound shipping and return shipping cost will not be refunded. Please allow 4 to 6 weeks for your refund to be processed.

## **Warranty**

To The Owner of this Product:

Thank you for purchasing one of Over Armour Offroad Cab Enclosures, Tops &/or Windshields!  
Below are the terms under which your product is covered under our manufacturer's warranty.

30 Day Warranty which includes and is not limited to replacing the enclosure, tops and/or windshield due to defect of the product. Please refer to the return policy in this case for more information.

1 Year Warranty includes any defect in material or workmanship within this time frame we will gladly correct the problem or replace the enclosure, tops &/or windshield. Upon submitting for the correction or replacement we will need to receive pictures of the defect in material or workmanship along with the receipt from the date of purchase.



Thank you,

Over Armour Offroad

[www.overarmouroffroad.com](http://www.overarmouroffroad.com)