

# Over Armour Offroad

2515 Bypass Rd. Flemingsburg, KY 41041  
606-845-7439

## Instructions for Installation and Care of John Deere Gator RSX 850i Full Cab with Aero-Vent Polycarbonate Windshield JD-850i-FC04

**Notice: Do not smoke inside the cab or expose the enclosure to direct flames. Cab is Flammable.**

1. Be sure to read these instructions thoroughly before opening and installing the John Deere Gator Cab Enclosure. The installation is best done when the temperature is 70 degrees F. or warmer. This is to help the adhesive Velcro adhere to the roll cage. If installation must be done in colder temps it helps to warm the Velcro at room temperature first.
2. Carefully open the carton and remove the rolled up Cab Enclosure on a large flat surface that is clean and free of dirt or other material that may soil or scratch the windows of the Cab.
3. The Full Cab with Aero-Vent Windshield has 4 different soft panels that work together to enclose the rear, sides and top of the roll cage. You will also receive an Aero-Vent Windshield that will have its own installation instructions. Below is the correct installation order for Mammoth Designs cab system. It will help to raise the bed prior to installing the cab enclosure.
4. Install the Aero-Vent Windshield first as shown in the instructions provided.
  - 1) Soft Doors (x2)
  - 2) Soft Rear Window
  - 3) Soft Top
5. Check over the parts included in the carton with the parts list shown below:

Velcro Hook strips:		
“ “	30 each	3” long
“ “	4 each	6” long
“ “	2 each	14” long
Para cord	2 each	80” long
Straps with Grommets	2 each	
Straps with Velcro	4 each	
Door Panels	2 each	
Rear Window	1 each	
Top Cap	1 each	
Snap studs	5 each (1 extra)	
6. **Soft Doors:** Start by holding the door panel up to the side of the roll cage and take a mental note or if possible mark the locations of the double-sided Velcro strips sewn to the edges of the door panels. Next take the 3” adhesive Velcro hook strips and place them around the inside roll cage where each of the double-sided strips hit the roll cage. It works best to start with the Velcro across the top of the door in order to hang the door in

place before attaching the Velcro down the front and rear of the door panel. Photos on next page show proper installation of double-sided Velcro.

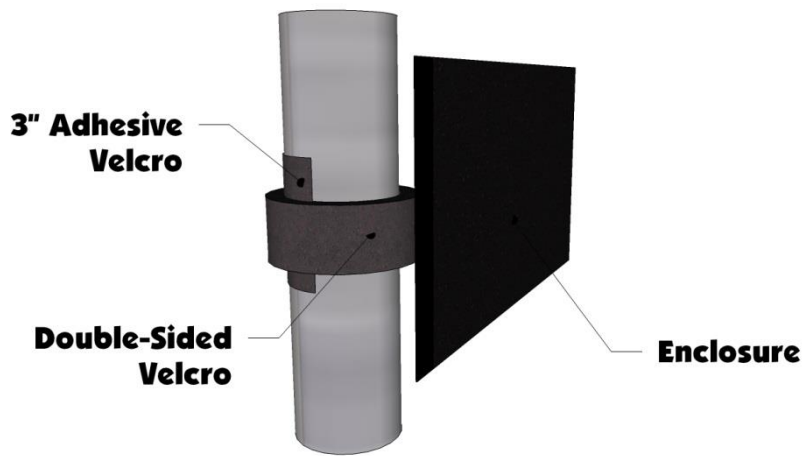
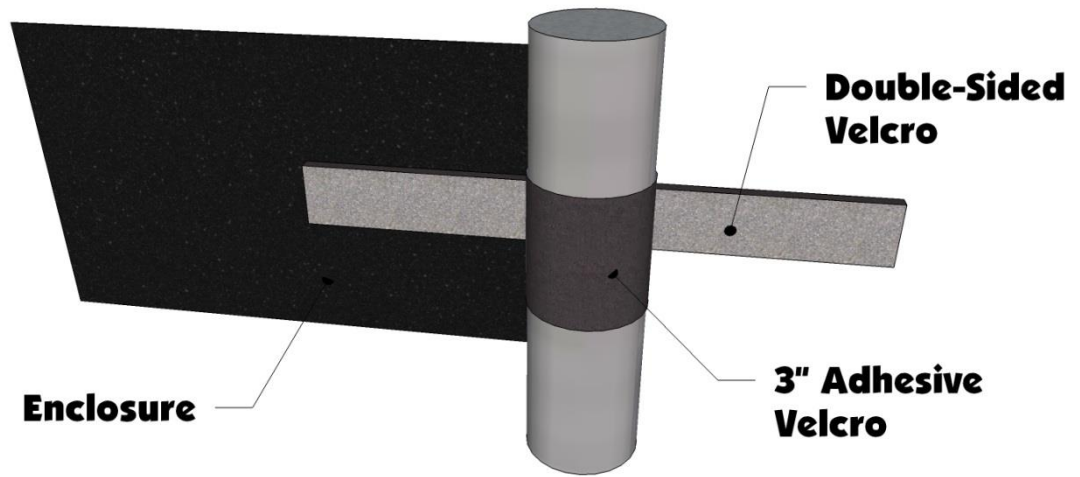

7. You will notice two snaps on the bottom front portion of the door. These snaps will attach to the front section of the plastic door that is stationary on the “4X4” Logo. **Install Tip: Insert the screw snap stud into the socket on the enclosure first. Then pull the enclosure down to where it should be located and push the screw into the plastic hard enough to leave a dimple mark. Remove the screw stud and then install the stud into the plastic using a #2 Phillips Screwdriver.**
8. The bottom of the door has magnets sewn to the edge that will hold to the metal strip across the top inside of the door panel. Magnets should lay on the door as shown below:



**9. Rear Window:** Installation of the Rear Window begins by attaching the two 14” adhesive Velcro strips to the horizontal bar that the brake light is on. The adhesive Velcro strips go on either side of the brake light facing upward and slight toward the front of the vehicle. Place the top of the Rear Window under and around the brake light and attach the two Velcro strips across the top of the Rear Window to the two adhesive Velcro strips on the bar. The photo below shows how this should look when attached.



10. Next step is to take the two 80” lengths of Para-cord and lace them together using the grommets down each side of the Doors and Rear Window. Begin at the top running the cord through the top hole in the Door and the Rear Window pulling two even length sections out. Then precede the lace the two panels together as you would a pair of shoes. Once the lacing is finished, tie the ends together and cut off any excess. Be sure to melt the ends to prevent fraying. The photos below show how this should look.



- 11. Top Cap:** Now that the Doors and Rear Window is installed all that is left is to install the top cap. Provided with your cab are several webbing straps, two that have grommet holes and four that are sewn to double-sided Velcro strips. For the purpose of this cab install you will be using two of each. Take the two straps with grommets and attach them to the windshield hardware. Use the bottom clamp on the top windshield section as shown in the photo below.



12. Now take the two straps sewn to the Velcro and attach them on the rear bar under the cab enclosure. This part can be a bit complicated but is not impossible. Find a good spot between the lacing and wrap the double-sided Velcro around the bar after placing one of the 3" adhesive Velcro strips on the backside. Then run the webbing through the lacing and up towards the top cap. When finished, it should look like the photo below.



13. Now take the Top Cap and place it over top of the vehicle and the enclosure. Make sure that it is centered and then take the straps and run them through the ladder lock buckles sewn in the corners and pull them tight. The straps lace through the buckle as shown in the diagram below.

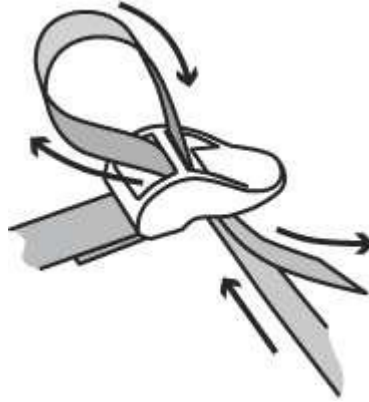

14. Lastly install the bent brace on the outside of the windshield so that the Top Cap is sandwiched between the two.
15. This should complete the installation of your Soft Door Rear Window Combo. The doors roll back when not needed. To do so make sure that the two webbing straps on each door should wrap around the back side of the roll bar and between the door and rear window. After unzipping fully, roll the door from front to back so that the roll is towards the inside of the vehicle. Once rolled up take the webbing strap and pull around the door to the Velcro strips sewn to the outside.

#### Cleaning and Storage Recommendations:

1. Before removing the Mammoth Cab for storage, make sure it is very clean in order to prevent scratching of the window panels. Clean with a soft rag or sponge using a mild liquid detergent soap and warm water solution. Never rub the windows with a dry cloth or rag! Let the Cab dry thoroughly before attempting to roll for storage.
2. It is important that the Cab be rolled up for storage rather than folding. Folding will cause damage to the windows!!! Carefully roll up the Cab similar to the way it was when it was packed at the factory. On a large, clean and flat surface, fold the doors over the rear panel first, then, interleave the top and windshield on top of the doors. Begin rolling the Cab into a roll approximately 8 inches in diameter. Put the rolled Cab back into the carton for storage at a normal room temperature. It is best not to expose the Cab to either extreme hot or cold temperatures when storing.
3. A special cleaner conditioner is available from Mammoth Designs that will greatly increase the service life of the Cab Enclosure. In addition, if additional hook and loop sets are needed, they can also be ordered.

## Return Policy

If for any reason you choose to return this product it must be returned within **30 days from date item is received**. You **MUST** package the product exactly **as it was originally packaged from the factory to get a full refund for the product!**

The vinyl windows should never be folded when packaging in the box or for storage purposes. Lay all the windows on top of each other with the canvas folded in between and the paper (if available) on both sides of the windows.

**All returned products will be inspected upon arrival at the production facility and must be in unused, factory new condition to receive refund - a 25% restocking fee will apply.**

If ordered from Over Armour Offroad please call at 606-845-7439 to gain a return authorization number, use our preferred shipping carrier (UPS) to return the item (unless the item is defective, you are responsible for paying the shipping to return the item.) **Any returns submitted to Over Armour Offroad without a return authorization number will be charged a 20% restocking fee.** If ordered from one of Over Armour Offroads many distributors', you must first call them and see what their return policy is. Once your item reaches our production facility, our customer satisfaction team will inspect your item to ensure unused, factory new condition. **NOTE: All windshields must be returned with the original protective film intact and not removed. Do NOT REMOVE if you have any intentions of returning the item. Refund/ replacement of a windshield will only be processed on items with original protective film or if the windshield is defective.**

Items must be properly packaged in the original shipping carton to protect them during transit and ensure your returned item arrives back factory fresh, and in new resalable condition (**any returned items that have been used, altered or damaged in any way will not be subject for a refund.**) All contents including instruction manuals, accessories, hardware, Velcro, etc. must be included in your return shipment. Only items in OEM factory new condition will be approved. Once returned items are received, credit will be issued to the original credit card/ payment method used for the purchase. Outbound shipping and return shipping cost will not be refunded. Please allow 4 to 6 weeks for your refund to be processed.

# Warranty

To The Owner of this Product:

Thank you for purchasing one of Over Armour Offroad Cab Enclosures, Tops &/or Windshields!  
Below are the terms under which your product is covered under our manufacturer's warranty.

30 Day Warranty which includes and is not limited to replacing the enclosure, tops and/or windshield due to defect of the product. Please refer to the return policy in this case for more information.

1 Year Warranty includes any defect in material or workmanship within this time frame we will gladly correct the problem or replace the enclosure, tops &/or windshield. Upon submitting for the correction or replacement we will need to receive pictures of the defect in material or workmanship along with the receipt from the date of purchase.

Thank you,

Over Armour Offroad  
[www.overarmouroffroad.com](http://www.overarmouroffroad.com)