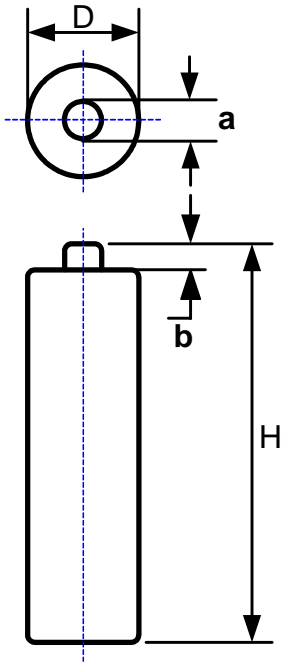

## TENERGY AA 2600mAh NiMH Battery

<b>Product Name:</b>	Tenergy NiMH AA	
<b>Product Number:</b>	10308	
<b>Battery Model:</b>	NiMH AA 2600mAh	
<b>Battery Chemistry:</b>	Nickel Metal Hydride	
<b>Dimension:</b>	Diameter (D): $14.5^{+0}_{-0.7}$ mm Height (H): $50.5^{+0}_{-1.5}$ mm Top Diameter (a): 4.6 - 5.5mm Top Height: 1.0 (minimum)	

### 1. SCOPE

The specification describes the technology parameters and testing standard for the NiMH AA size cells supplied by TENERGY CORPORATION.

### 2. CHARACTERISTICS

2-1.Nominal voltage	1.2V
2-2.Nominal capacity	2600mAh
2-3.Minimum capacity	2500mAh
2-4.Charging	
Standard charging	250mA for 16 hours
Quick charging	500mA for 7 hours
Rapid charging	1250mA for 2.4hours, $-\Delta V=5mV$



---

2-5.End voltage of discharge	1.0V
2-6.Temperature (recommended)	
Standard charge	0~40°C
Quick charge	10~40°C
Rapid charge	10~30°C
Discharge:	-10~50°C
Storage: Less than 30 days	-20~50°C
Less than 90 days	-20~40°C
Less than 1 year	-20~30°C
2-7.Relative humidity	45~85%
2-8.Weight	Approx. 26.5 g

### 3. APPEARANCE

There shall be no practical damage such as conspicuous liquid electrolyte leakage, flow and dirt under conditions of storage or operation as specified herein.

### 4.ELECTRICAL CHARACTERISTICS

#### 4-1.Testing conditions

The battery shall be evaluated within 1 month from the arrival date.

Unless otherwise stated in these specifications, the following test shall be carried out in an ambient temperature of  $20\pm 5^{\circ}\text{C}$ , relative humidity of  $65\pm 20\%$ .

#### 4-2. Internal resistance

Within 1 hour after standard charge, the internal resistance is not greater than  $35\text{m}\Omega$ , as tested by 1000Hz AC source.

#### 4-3.Capacity

4-3-1.The battery unit shall be capable of supplying 500mA continuous discharge current for



---

a minimum of 300 minutes to the 1.0V end voltage within 1 hour after being standard charged.

4-3-2.The battery unit shall be capable of supplying 1250mA continuous discharge current for a minimum of 110minutes to the 1.0V end voltage within 1 hour after being standard charged.

4-3-3.The battery unit shall be capable of supplying 2500mA continuous discharge current for a minimum of 52 minutes to the 0.9V end voltage within 1 hour after being standard charged.

#### 4-4.Temperature characteristics

4-4-1.Within 1 hour after being standard charged at 40°C, the battery unit shall be discharged at 20°C, at a current of 250mA to 1.0V end voltage, discharge time shall be a minimum of 210 minutes.

4-4-2. Within 1 hour after being standard charged at 20°C, the battery unit shall be discharged at 0°C, at a current of 250mA to 1.0V end voltage, discharge time shall be a minimum of 210 minutes.

#### 4-5.Charge (capacity) retention

After being standard charged battery unit is stored for 28 days at 20±2°C, the battery unit shall be discharged at 20°C, at a current of 250mA to 1.0V end voltage; discharge time shall be a minimum of 240 minutes.

#### 4-6.Overcharge

Within 1 hour after being charged at a current of 250mA for 48 hours, the battery unit shall be discharged at 20°C, at a current of 250mA to 1.0V end voltage, discharge time shall be a minimum of 300 minutes.

#### 4-7.Overdisrcharge

After being standard charged battery unit discharged with 2ohm load for 7 days, and then discharged battery unit at a current of 250mA to 1.0V end voltage within 1hour after standard charged, discharge time shall be a minimum of 270 minutes.

#### 4-8.storage



charge	storage	discharge	voltage	remains capacity
250mA for 16 hours	6 months at 20°C	500mA to 1.0V	≥1.27V	≥80%
250mA for 16 hours	1 year at 20°C	500mA to 1.0V	≥1.25V	≥65%
250mA for 16 hours	3 months at 40°C	500mA to 1.0V	≥1.25V	≥65%
250mA for 16 hours	21 days at 60°C	500mA to 1.0V	≥1.25V	≥65%

4-9.Endurance in cycles

Prior to the endurance in cycles test, the battery unit shall be discharged at 210mA to 1.0V end voltage. A battery unit shall be capable of 500 minimum cycles under the conditions as follows.

Cycle	Charge	Rest	Discharge
1	250mA for 16hours	None	500mA×140minutes
2~48	250mA for 190minutes	None	500mA×140minutes
49	250mA for 190minutes	None	500mA to 1.0V
50	250mA for 16hours	1h to 4h	500mA to 1.0V

Cycles 1 to 50 shall be repeated until the discharge time on any 50<sup>th</sup> cycle becomes less than 3 hours. At this stage, repeat 50<sup>th</sup> cycle, if the discharge time is less than 3 hours again the test is terminated.

Note: If battery unit voltage drops below 1.0V, discharge shall be discontinued.



#### 4-10.Safety

##### 4-10-1.Continuous low-rate charging

The battery unit shall not explode when it is charged at 21mA~35mA for 28 days. However, it is acceptable for the battery unit to sustain leakage of battery fluid and show a change in appearance.

##### 4-10-2.Forced discharge

The battery unit shall not explode when it is reverse-charged at 800mA for 1 hour after being discharged at 250mA to 1.0V end voltage. However, it is acceptable for the battery unit to sustain leakage of battery fluid and show a change in appearance.

#### 4-11.Vibration

The battery unit shall not show a change in appearance, leak or explode, when it is tested under the following conditions After being standard charged

Frequency	10~55Hz
Amplitude	0.76mm
Rate of frequency variety	1 Hz/minute
Duration	90 minutes /axis (axis: X、 Y、 Z) 270 minutes in all

### 5. ENVIRONMENTAL PROTECTION REQUIREMENT

5-1. The requirement on Hazardous Substances in the Products should comply with 2006/66/EC and TENERGY's criterion on HS.

### 6. TRANSPORT

6-1. To ensure battery safety during delivery, SOC (State Of Charge) must be below 35%, inside temperature of container could not be over 35°C. Product holder should be responsible for any possible loss during delivery if above conditions cannot be met completely.



6-2. Inside temperature of container must be below 20°C if any client requires SOC (State Of Charge) above 35%, the distance between battery master cartons should be not less than 10cm in container, and coercive air cross ventilation system is required in container to ensure even temperature for each master carton. Product holder should be responsible for any possibly accidental loss if above conditions cannot be met completely.

## **7. PRECAUTION:**

Please keep in mind the following points when designing and manufacturing equipment. Please insert in your instruction manual. To prevent equipment malfunctions from affecting the batteries, be sure to use protection devices for electrical circuits and batteries.

### **⚠ Danger!**

- Failure to carefully observe the following procedures and precautions can result in leakage of battery fluid (electrolyte), heat generation, explosion, fire and serious personal injury!
- Never dispose of TENERGY batteries in a fire or heat them.
- Do not connect the (+) positive and (-) negative terminals of TENERGY batteries together with electrically conductive materials, including lead wires. Do not transport or store TENERGY batteries with their uncovered terminals or connected with a metal necklace or other electrically conductive material. When carrying or storing batteries, use a special case.
- Only charge TENERGY batteries using those specific chargers that satisfy TENERGY's specifications. Only charge batteries under the conditions specified by TENERGY.
- Never disassemble TENERGY batteries. Doing so may cause an internal or external short circuit or result in exposed material of battery reacting chemically with the air. It may also cause heat generation, explosion and fire. Also, this is dangerous as it may cause splashing of alkaline fluid.
- Never solder lead wires directly on to TENERGY batteries.
- The (+) positive and (-) negative terminals of TENERGY batteries are predetermined. Do not force the terminals to connect to a charger or equipment. If the terminals cannot be easily connected to the charger or the equipment, check if the (+) and (-) terminals are incorrectly



positioned.

- The gas release vent which release internal gas is located in the (+) positive terminal of the TENERGY battery. For this reason, never deform this section or cover or obstruct its gas release structure.
- Do not directly connect TENERGY batteries to a direct power source or the cigarette lighter socket in a car.
- TENERGY batteries contain a strong colorless alkaline solution (electrolyte). The alkaline solution is extremely corrosive and will cause skin damage. If any fluid from a TENERGY battery comes in contact with user's eyes, they should immediately flush their eyes and wash them thoroughly with clean water from the tap or another source and consult a doctor urgently. The strong alkaline solution can damage eyes and lead to permanent loss of eyesight.
- When TENERGY batteries are to be incorporated in equipment or housed within a case, avoid air-tight structures, as this may lead to the equipment or the case being damaged or may be harmful to users.

## 8. WARRANTY

TENERGY will be responsible for replacing the battery against any defects or poor workmanship for six months from the date of shipping.

Any other problems caused by malfunction of the equipment or misuse of the battery are not under this warranty.

### **Notice:**

To assure safety, please consult to the TENERGY technical staff for your applications including electrical specifications, mechanical designs, protective devices and any special specification.

TENERGY reserve the right to alter or amend the design, model and specification without prior notice.



Appendix

Performance Curve

