

Features

- The world's smallest 3800 lumen LED flashlight
- Utilizes 4 x CREE XM-L2 LEDs
- Integrated multi-function OLED display
- Thermal protection circuit prevents overheating
- Compatible with both 18650 Li-ion and CR123 batteries
- Intelligent charging circuit with voltage detection charges safely and rapidly
- Exceptionally long runtimes using 4 x 18650 Li-ion or 8 x CR123 batteries
- Capable of using 1 x 18650 or 2 x CR123 batteries in emergency situations
- Eight rapidly switchable brightness levels and modes to select from
- Innovative single button two-stage switch provides a user-friendly interface (Patented)
- Toughened ultra-clear mineral glass with anti-reflective coating
- Integrated "Precision Digital Optics Technology" provides extreme reflector performance
- Stainless steel bezel ring protects core components from damage
- Constructed from aerospace-grade aluminum alloy
- HAIII military grade hard-anodized
- Waterproof in accordance with IPX-8 (submersible to two meters)

Dimensions

Length: 142mm (5.6")
 Head diameter: 68 mm (2.68")
 Head side-length: 57mm (2.24")
 Tube diameter: 50mm (1.96")
 Weight: 438g (15.45oz) (without battery)

Accessories

Charger, quality holster, lanyard, and spare O-ring

Battery Options

	SIZE	Nominal voltage	Compatible
18650 Rechargeable Li-ion battery	18650	3.7V	Yes (Recommended and can be recharged)
Primary Lithium battery *	CR123	3V	Yes (Compatible but can NOT be recharged)
Rechargeable Li-ion battery *	RCR123	3.7V	Yes (Compatible but can NOT be recharged)

Warning: Charge 18650 rechargeable Li-ion batteries only, do not attempt to charge non-rechargeable batteries, CR123 or RCR123 batteries.

Output & Runtime

FL1 STANDARD	TURBO	HIGH	MID	LOW	LOWER
	3800 LUMENS	1850 LUMENS	600 LUMENS	150 LUMENS	3 LUMENS
	45min	2h30min	8h15min	48h	1000h
	1h	2h15min	5h45min	32h	750h
	445m (Beam Distance)				
	49000cd (Peak Beam Intensity)				
	1.5m (Impact Resistant)				
	IPX-8, 2m (Waterproof AND Submersible)				

NOTICE

The above data has been measured in accordance with the international flashlight testing standards ANSI/NEMA FL1 using 4 x Nitecore 18650 (3.7V 2600mAh) and 8 x Nitecore CR123 (3V 1550mAh batteries under laboratory conditions. The data may vary during real-world use due to battery type, individual usage habits and environmental factors.

NITECORE (SYSMAX) is a member of PLATO, participating in and helping to develop the ANSI FL1 standard of measurement. Product testing data is in accordance with these internationally recognized scientific standards.

Operation instructions

Battery installation

Unscrew the tailcap, insert 4 x 18650 Li-ion or 8 x CR123 batteries with the positive (+) end pointing toward the flashlight head. Replace the tailcap. In special circumstances, such as emergency situations, between one and three 18650 Li-ion or two and six CR123 batteries may be used.

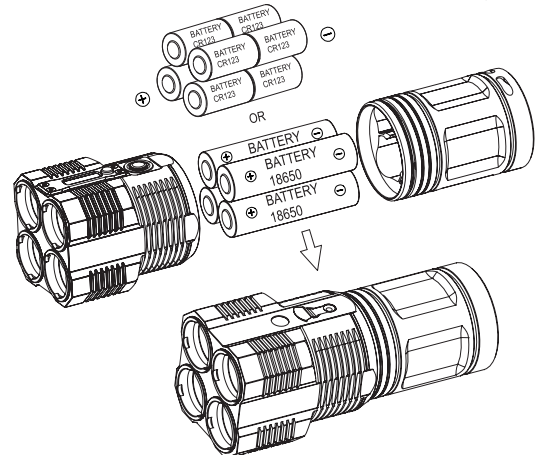

Note 1: Due to the strain using less than 4 x 18650 or 8 CR123 places on batteries, Nitecore recommends using this feature only when necessary and for short periods of time. Please see point number 1 in the warning below.

Note 2: After loading batteries, "NITECORE" will be displayed on the OLED screen for 2.5 seconds followed by battery voltage (accurate to 0.01V) after which the TM26 will enter into standby mode.

WARNING

1. Using less than 4 x 18650 or 8 x CR123 batteries can lead to turbo mode malfunctioning, can trigger the overload protection circuit in Li-ion batteries and can even lead to explosion of CR123 batteries. As such Nitecore recommends this function is used with caution and only when necessary.
2. Insert batteries with the positive (+) end pointing toward the flashlight head.
3. Do not mix rechargeable and non-rechargeable batteries.
4. Do not mix batteries of different types/brands.
5. Do not mix batteries of different charge levels.
6. Do not use lithium batteries without a protected circuit board.
7. This product does not support unprotected 18650 Li-ion batteries. Please also ensure that all the 18650 batteries used in the TM26 have a button top configuration or they will not make contact with terminals in the battery compartment. We recommend Nitecore 18650 batteries for the best performance and reliability.

Charging the TM26

1. Connect the charging cable to the flashlight and the A/C power adapter to the wall outlet as shown in the adjacent image. Fully charging four depleted 18650 batteries takes approximately 7 hours.
2. Under normal charging conditions, the on/off switch's blue indicator light will blink twice every second and the OLED screen will display the word "Charging..." together with battery voltage.
3. If a problem is detected while charging the TM26 will stop charging, the blue indicator will blink rapidly and the OLED display will show the word "ERROR". This is usually caused by faulty or incorrectly inserted batteries.
4. When charging is complete, the blue indicator will remain on, and "CHG.FINISHED" along with battery voltage will be displayed on the OLED screen.

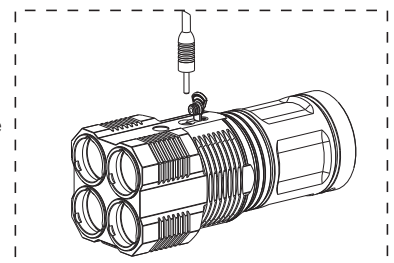

General Operation

NB: The TM26 utilizes a 2-stage switch similar to a camera shutter button. The light's numerous functions are selected according to the depth the switch is pressed.

The TM26 has two modes: Daily mode and Turbo mode. With the TM26 turned off, pressing the switch partway down will activate Daily mode. Alternatively, with the TM26 turned off, pressing the switch all the way down will activate turbo mode. The TM26 is turned off by pressing the switch all the way down.

Brightness Selection In Daily Mode

1. With the TM26 turned on in Daily mode, press the switch partway down to select a brightness level of ultra-low, low, medium or high. The selected brightness level will be memorized when the light is turned off.
2. With the TM26 turned on in Daily mode, press the switch partway down and hold to enter into turbo mode. A second partway press will revert back to the brightness level last used.

Bright Selection In Turbo Mode

With the TM26 turned on in Search/Turbo mode, partway presses of the button will cycle between high and ultra-high mode. There is no memory function in Search/Turbo mode.

Momentary Daily / Turbo Mode

1. With the TM26 turned off, press the switch partway down and hold to activate Momentary Daily mode. Release the switch to turn the light off again.
2. With the TM26 turned off, press the switch all the way down and hold to enter into Momentary Turbo mode. Release the switch to turn the light off again.

Standby Mode

With the TM26 turned on, press the switch all the way down and release within one second to enter into standby mode. In this mode, the light will consume small amounts of power to maintain the settings in the MCU (micro control unit) but appear to be turned off. When in standby mode the power indicator light will flash once every three seconds to show the location of the light.

OLED Display

1. When the TM26 is turned on, the OLED display will activate automatically and show lumen output, brightness mode, battery voltage, battery status, approximate runtime and temperature. After displaying this information for several seconds the OLED display will turn off. The display can be reactivated by pressing the display switch and the information can be cycled through with subsequent presses of the switch.
2. When in Standby mode, a single press of the OLED display switch will activate the OLED and display battery voltage for 10 seconds.
3. When using Nitecore's NBP52 high-performance battery pack, the actual runtime will be twice the figure displayed on the OLED panel.

NB: The TM26 has an integrated thermal protection circuit which prevents overheating. Please refer to the "Thermal protection" section of this manual for details.

Special Strobe / SOS mode and Location Beacon

With the light turned on, press the switch all the way down twice in quick succession to access strobe mode. When in strobe mode, press the switch partway down to cycle through SOS, location beacon and strobe modes. To select any of these modes simply release the switch when it is displayed. To turn off the light (enter into standby mode) fully press and release the switch.

NB: When in any of the special modes, the OLED display will remain on to display which mode is being used.

Demonstration mode

When entering standby mode simultaneously press and hold the display switch and the on/off switch to enter into Demonstration mode. In Demonstration mode, the OLED screen will cycle through the TM26's various messages. Simply press any button to exit Demonstration mode.

Lockout Function

With the light turned on, press the switch all the way down and hold for more than one second. The light will turn off and enter into lockout mode. Lockout mode consumes almost no battery power and prevents the light from accidentally turning on. Simply press the switch and hold for more than one second to exit lockout mode.

NB: If the display button is pressed when in lockout mode, the OLED display will show the words "LOCK OUT" as a reminder.

Power Tips

1. With the light switched on, the power indicator will blink once every two seconds when power levels reach 50%.
2. With the light switched on, the power indicator will blink rapidly when power levels are low.

Note: When the light is being used in ultra-low mode, the blue power indicator will turn off to help conserve power.

Thermal protection

As the TM26 is very compact, extended operation in Turbo mode will cause the body temperature to continually rise, thus, making it too hot to comfortably hold. As a result, Nitecore does not recommend using the TM26 in Turbo mode for extended periods. The TM26 has an integrated thermal protection circuit which prevents overheating. With the light turned on in Search/Turbo mode, for user safety and to protect the flashlight from failure, the TM26 will automatically reduce its output to prevent overheating once it has reached 60 degrees.

Precaution: When the flashlight is hot, do not attempt to cool it by submerging it in liquid. Due to the differences in internal and external air pressure the TM26 may suffer irreparable water damage.

Changing / Charging Batteries

When the power indicator blinks rapidly it means the batteries need to be replaced or recharged. Alternatively if the light becomes dim or unresponsive to adjustment this also indicates batteries need to be replaced or recharged.

Maintenance

Every 6 months, threads should be wiped with a clean cloth followed by a thin coating of silicon-based lubricant.

Warranty Service

All NITECORE® products are warranted for quality. DOA / defective products can be exchanged for replacement through a local distributor/dealer within the 14 days of purchase. After 14 days, all defective / malfunctioning NITECORE® products will be repaired free of charge for a period of 18 months from the date of purchase. After 18 months, a limited warranty applies, covering the cost of labor and maintenance, but not the cost of accessories or replacement parts.

The warranty is nullified in all of the following situations:

1. The product(s) is/are broken down, reconstructed and/or modified by unauthorized parties.
2. The product(s) is/are damaged through improper use.
3. The product(s) is/are damaged by leakage of batteries.

For the latest information on NITECORE® products and services, please contact your national NITECORE® distributor or send an email to service@nitecore.com

SYSMAX ind.

SYSMAX Industry Co., Ltd.

TEL: +86-20-83862000

FAX: +86-20-83882723

E-mail: info@nitecore.com

Web: www.nitecore.com

Address: Rm1407-08, Glorious Tower, 850 East Dongfeng Road, Guangzhou, China 510600

 Please follow our facebook for more info: NITECORE Flashlights

