

KRU PS

La Glacière

Model #358

Modèle #358

Modelo #358

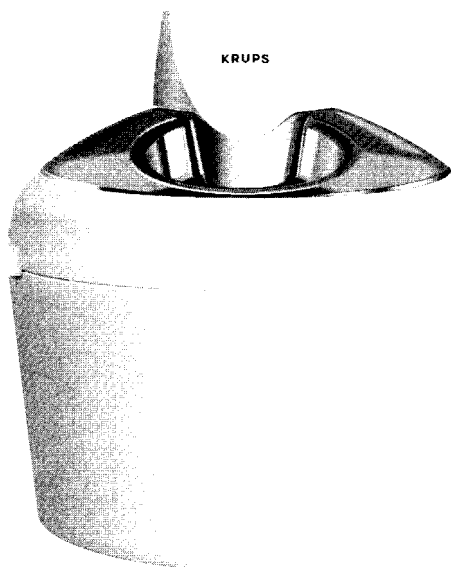

USA Instructions for Use

CAN Instruction Book
Manuel d'instruction

MEX Instrucciones de Uso

Krups La Glacière

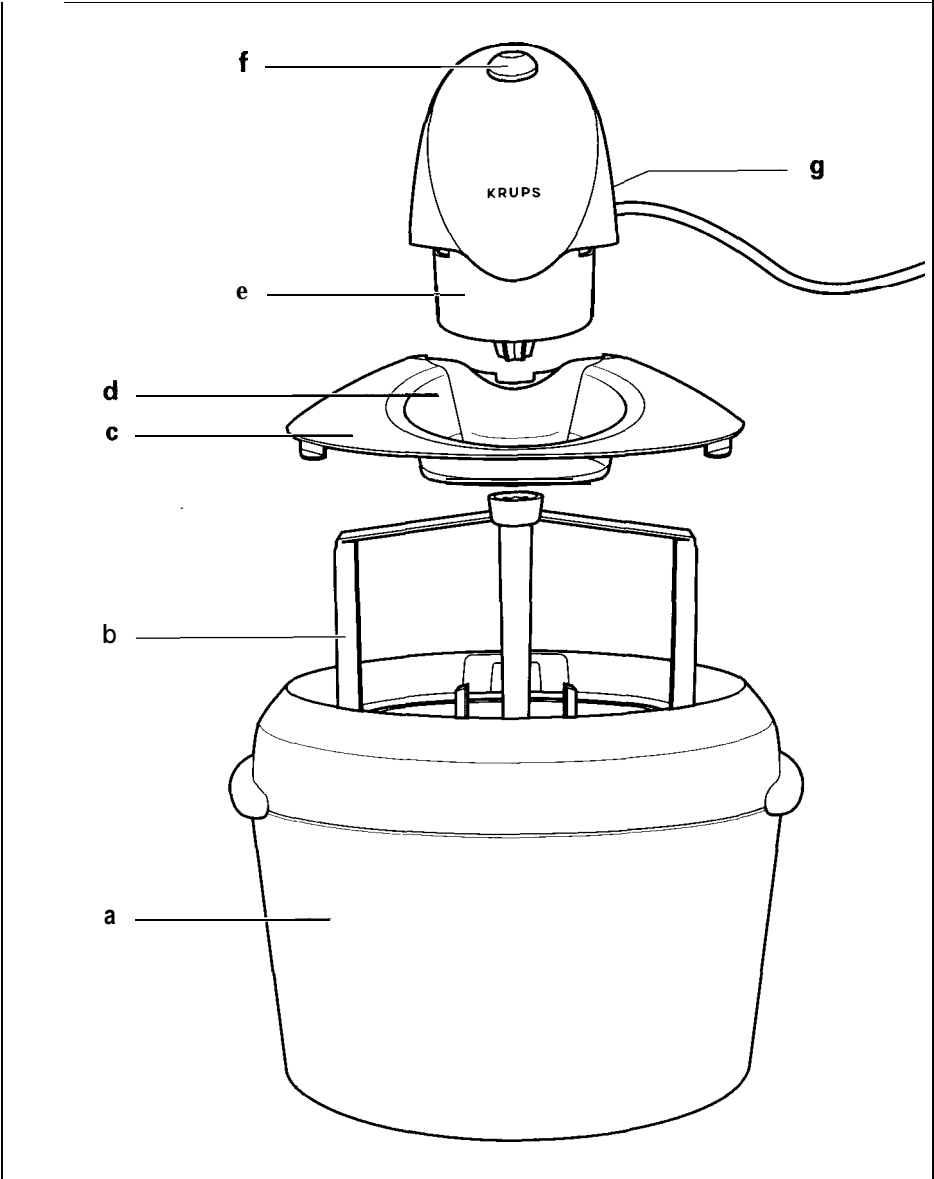

USA

- a: Freezing cylinder
- b: Paddle
- c: Lid
- d: Feeder hole
- e: Motor unit
- f: ON/OFF switch
- g: Release button

CAN

- a: Cuve réfrigérante
- b: Palette
- c: Couverture
- d: Orifice d'alimentation
- e: Bloc-moteur
- f: Interrupteur marche-arrêt
- g: Bouton de déverrouillage

MEX

- a: Tazón congelador
- b: Aspas
- c: Tapa
- d: Orificio alimentador
- e: Base motor
- f: Switch ON/OFF
- g: Seguro para la base motor

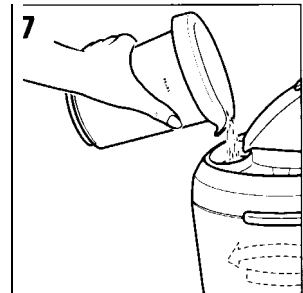
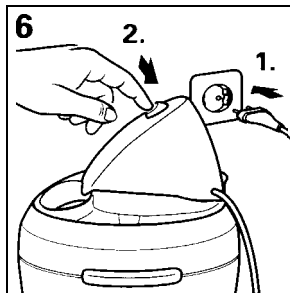
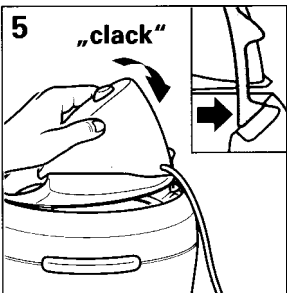
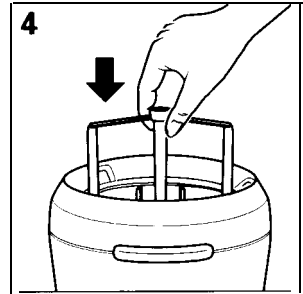
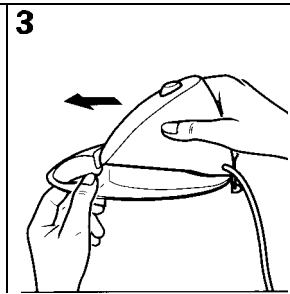
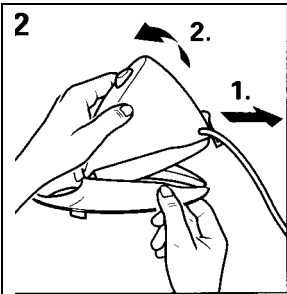
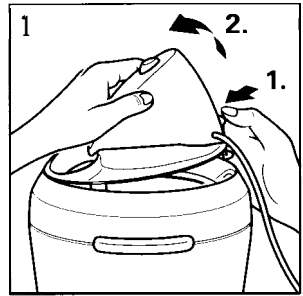

Table of Contents

Description	Page 3
Important Safeguards	Page 6
Before first use	Page 9
Freezing the cylinder bowl	Page 9
Making Ice cream	Page 9
Cleaning	Page 10
Helpful hints	Page 10
Waste disposal	Page 11
Recipes	Page 11
Warranty	Page 13
Guarantee of Performance	Page 14

IMPORTANT SAFEGUARDS

When using electrical appliances, basic safety precautions should always be observed, including the following:

- Read all instructions carefully.
- To protect against risk of electric shock, do not put base of appliance in water or any other liquid.
- Close supervision is necessary when any appliance is used by or near children.
- Unplug from outlet when not in use, before putting on or taking off parts, and before cleaning.
- Avoid contact with moving parts. Keep hands, hair, clothing, as well as spatulas and other utensils away during operation to reduce the risk of injury to persons, and/or damage to the appliance.
- Do not operate any appliance with a damaged cord or plug, or after the appliance malfunctions, or is dropped or damaged in any manner. Return the appliance to an authorized KRUPS Service Center (see Guarantee of Performance) for examination, repair or electrical or mechanical adjustment.
- The use of attachments not recommended or sold by KRUPS may result in fire, electric shock or injury.
- Do not use outdoors.
- Do not let cord hang over edge of table or counter, or touch hot surfaces.
- Keep hands and utensils out of cylinder bowl while in use to reduce the risk of injury to persons or to the appliance itself. **DO NOT USE SHARP OBJECTS OR UTENSILS INSIDE THE CYLINDER BOWL!** Sharp objects will scratch and damage the inside of the cylinder bowl. A rubber spatula or wooden spoon may be used, when the appliance is in the “off” position.

- This appliance is for household use. Any servicing other than cleaning and user maintenance should be performed by an authorized KRUPS Service Center.

SAVE THESE INSTRUCTIONS

CAUTION

This appliance is for household use. Any servicing other than cleaning and user maintenance should be performed by an authorized service representative.

Do not immerse base in water.

To reduce the risk of fire or electric shock do not remove the base. No user serviceable parts inside. Repair should be done by authorized service personnel only.

- Check voltage to be sure that the voltage indicated on the name plate agrees with your voltage.
- Never use warm or hot water to fill the water container! Use cold water only.
- Keep your hands and the cord away from hot parts of the appliance during operation.
- Never clean with scouring powders or hard implements.
- Do not place or use the appliance on hot surfaces, such as stoves, hotplates, or near open gas flames.
- Do not expose the freezing cylinder to temperatures above 105 °F/41 °C. Do not clean freezing cylinder in dishwasher.
- Do not unplug the unit by pulling on the cord.

SPECIAL CORD SET INSTRUCTIONS

Regarding your Cord Set:

- A. A short power-supply cord is to be provided to reduce risks resulting from becoming entangled in or tripping over a longer cord.**
- B. Longer extension cords are available and may be used if care is exercised in their use.**
- C. If a long extension cord is used, (1) the marked electrical rating of the extension cord should be at least as great as the electrical rating of the appliance, (2) if the appliance is of the grounded type, the extension cord should be a grounding-type 3-wire cord, and (3) the longer cord should be arranged so that it will not drape over the counter top or table top where it can be pulled on by children or tripped over.**
- D. This appliance has a polarized plug (one blade is wider than the other). As a safety feature, this plug will fit in a polarized outlet only one way. If the plug does not fit fully in the outlet, reverse the plug. If it still does not fit, contact a qualified electrician. Do not attempt to defeat this safety feature.**

Thank you for purchasing the KRUPS "La Glaciere" ice cream maker. This product belongs to the KRUPS line of high-quality, top performing appliances.

The "La Glaciere" lets you create unlimited ice cream flavors, whip up luscious sorbets, sherbets, frozen yogurt - even your favorite frozen drinks in just 20-40 minutes!

Your KRUPS "La Glaciere" has the following features:

- **Double Insulated "Quick Freeze" Bowl**
Double walls keep the cylinder bowl colder, longer for better freezing results. Liquid located within the walls provide thorough and even freezing throughout use.
- **See-Thru Lid with Feeder Hole**
Let's you conveniently keep an eye on the freezing process. Feeder hole allows you to add ingredients without disturbing the freezing process.
- **"ON/OFF" Button**
Easy to use and fully automatic. Takes all the guesswork out of making frozen desserts.
- **Compact Design**
Base is compact and requires minimal counterspace. The anti-slip rubber feet prevent movement during use.

Before first use

Remove all literature and packing materials from inside the ice cream maker.

- Press the release button at the rear of the motor unit, and lift lid upward (figure 1).
- Slide the motor unit out of the lid (figure 2).

Wash the freezing cylinder, lid and paddle in warm, soapy water. Be sure to rinse and dry all parts thoroughly.

Do not immerse motor unit in water. To clean, wipe with a damp cloth.

Freezing the cylinder bowl

The most important step in making frozen desserts is to make sure that the cylinder bowl is properly frozen. KRUPS "La Glaciere" features a double insulated bowl and requires thorough freezing. For best results, the cylinder should be placed upright in the back of your freezer, where the temperature is coldest.

Making sure that the cylinder bowl is washed and thoroughly dried, wrap the cylinder bowl in a plastic bag and place in back of freezer or where freezer compartment is the coldest. Wrapping your cylinder bowl in a plastic bag will guard against freezer burn. The length of time necessary to properly freeze the cylinder bowl will depend upon how cold the freezer temperature is.

Freezer Temperature	Approximate minimum time for cylinder to properly freeze
-30°C/-22°F	8-9 hours
-25°C/-13°F	12-13 hours
-18°C/0°F	20-22 hours
-15°C/5°F	24 hours or more

As there is liquid in between the cylinder walls, shake the container to check ideal freezing condition; you should not hear any liquid moving within the walls.

NOTE:

Continually storing the cylinder bowl in the freezer allows you the flexibility to make your favorite frozen dessert at a moment's notice.

Making ice cream

You can make up to 1 1/2 quarts (1.5 L) of ice cream in the "La Glaciere". Prepare ice cream mixture according to recipe. The maximum amount must not exceed 1 quart (1 L) of liquid, due to an increase in volume during preparation.

If using your own recipes, adapt the volume of mixture to this amount.

- To assemble the ice cream maker, slide the motor unit onto the lid until it locks in place (figure 3).

Remove freezing cylinder (a) from freezer.

- Insert paddle into cylinder (figure 4).

- Insert the tabs on the lid into the slots of the freezing cylinder, then lock rear of lid onto container (figure 5).

You will hear another “clack”. Make sure that motor and paddle are connected correctly.

- Insert plug into outlet, then turn the unit on immediately (figure 6).

This will prevent the paddle from freezing on the cylinder.

- Pour the prepared ice cream mixture through the feeder hole into cylinder (figure 7).

NOTE: It is extremely important that the cylinder be used immediately after it is removed from the freezer, as it begins to thaw once removed. Make sure that the ice cream mixture is ready first.

Leave the machine on for approximately 20-40 minutes, or until the mixture reaches the desired consistency. Do not turn the appliance off during use, as the mixture may freeze and prevent the movement of the paddle.

To add ingredients after the freezing process has begun, gently add them through the feeder hole (d).

To avoid overheating of the motor, the direction of rotation will change if the mixture becomes too thick. If the direction of rotation continues to change, the mixture is completely prepared; turn off appliance immediately.

- To remove lid, press the release button on the rear of the motor unit, and lift lid from cylinder (figure 1).

Remove paddle from ice cream. Only use rubber, plastic or wooden utensils to serve from the cylinder bowl. Metal spoons may damage the surface of the bowl.

To further harden the ice cream, you may put the cylinder with the ice cream into the

freezer for a short period of time (no more than 30 minutes). Long term freezing, however, should be done in an airtight container.

Cleaning

The lid and paddle can be washed in the dishwasher (top rack only). The freezing cylinder should be cleaned in warm water and mild detergent, then dried thoroughly.

Never replace cylinder in freezer if it is still wet. Do not use sharp utensils, scouring pads, or abrasive detergents when cleaning freezing cylinder.

The motor unit can be cleaned by using a damp cloth. Never immerse motor unit in water.

Helpful hints

- Some recipes require the mixture to be pre-cooked. Make the recipe at least one day ahead. This will allow the mixture to cool completely and volumize. Pre-chilling the base mixture is strongly recommended. Never try to shortcut.
- Uncooked recipes will yield best results when an electric mixer is used to beat eggs and sugar. This helps volumize the mixture.
- Most ice cream recipes are a combination of cream, milk, eggs and sugar. You can use any type of cream you like, but the type of cream you use will have a big impact on the rich flavor and creamy texture. The higher percentage of fat, the richer the ice cream and the softer the texture. For example, heavy cream has at least 36% fat, followed by: whipping cream (30%), coffee or light cream (18%) and half & half (10%). Any combination can be used, but make sure the liquid measurement remains the same. For example, lighter ice creams can be made by using more milk than cream, or by eliminating cream altogether. Skim milk will work, but there will be a noticeable difference in texture.

- Ice cream mixtures will stay fresh in the refrigerator for several days. Be sure to shake well before adding to the cylinder.
- When pouring mixture into the cylinder, be sure to stop 1" (2.5 cm) from the top, as mixture will volumize during the freezing process.
- Alcohol inhibits the freezing process. To add alcohol to a recipe, do so when mixture is semi-stiff.
- The result in the taste of a sorbet will depend greatly on the ripeness and sweetness of the fruit and juice. Taste the fruit before adding to the recipe. If it is too tart, add sugar; if the fruit is very ripe, decrease or omit the sugar.
Keep in mind that freezing subdues sweetness, so the recipe will not be quite as sweet when frozen.
- For those who are diet-conscious, artificial sweeteners can be used as a substitute for sugar. NOTE: Only add artificial sweeteners to mixtures that are cold or have completely cooled. When a recipe calls for heating liquid to dilute sugar, omit the heating process and simply stir in the sweetener until it is well dissolved.
 - 1 packet of sweetener = 2 teaspoons (10 ml) of sugar
 - 6 packets = 1/4 cup (60 ml)
 - 8 packets = 1/3 cup (75 ml)
 - 12 packets = 1/2 cup (125 ml)
- Do not use stiff mixtures (i.e. whipped cream, frozen liquids). The mixture should be liquid when preparation starts.
- When adapting your own recipes to the maximum amount of 1 quart (1 L), you should adapt all ingredients with the same percentage. If this is not done, the structure of the final preparation may vary.
- Do not operate the appliance longer than required. If after 40 minutes the mixture is not yet solid, or has thawed again, do not continue. Possible reasons for failure are:
 - the cylinder was not cold enough
 - the mixture was too warm
 - the proportion of ingredients was incorrect.

- Do not store prepared ice cream in the freezer for more than a few days.

Waste disposal

The liquid in the freezing cylinder contains no toxic materials. The cylinder can be disposed of as normal household waste.

Recipes

Vanilla Ice Cream

1 cup (250 ml) milk
 1/2 (125 ml) cup sugar
 2 eggs
 2 cups (500 ml) cream
 2 tsp. (10 ml) vanilla extract

Warm the milk in a small pan. Whisk the eggs with the sugar in a separate bowl. Slowly add warm milk to mixture continuing to whisk. Pour mixture back in the pan and heat slowly until thickened, stirring constantly (looks like very liquid pudding). Do not boil! Let cool to room temperature, add cream and vanilla and chill.

Variations:

Coffee Ice Cream
 dilute 2 tsp. (10 ml) instant coffee in the hot mixture

- Peppermint Ice Cream
 replace the vanilla by 2 tsp. (10 ml) peppermint extract

Chocolate Ice Cream

1 cup (250 ml) milk
 2/3 cup (150 ml) sugar
 1/3 cup (75 ml) cocoa powder
 1 egg
 2 cups (500 ml) cream
 1 tsp. (5 ml) vanilla extract

Mix milk, egg and sugar in a small pan. Heat slowly until thickened, stirring constantly (looks like very liquid pudding). Do not boil! Mix in cocoa powder. Let cool to room temperature, add cream and vanilla and chill.

Coconut Ice Cream

1 cup (250 ml) milk

2/3 cup (150 ml) sugar

2 eggs

2 cups (500 ml) cream

1/4 cup (60 ml) grated coconut

1/2 tsp. (2 ml) vanilla extract

Mix milk, egg and sugar in a small pan. Heat slowly until thickened, stirring constantly (looks like very liquid pudding). Do not boil! Mix in coconut. Let cool to room temperature, add cream and vanilla and chill.

Rum Raisin Ice Cream

3/4 cup (175 ml) raisins

1/2 cup (125 ml) rum

pour rum over raisins, cover, and let stand overnight

1 cup (250 ml) milk

1/2 cup (125 ml) sugar

2 eggs

2 cups (500 ml) cream

Warm the milk in a small pan. Whisk the eggs with the sugar in a separate bowl. Slowly add warm milk to mixture continuing to whisk. Pour mixture back in the pan and heat slowly until thickened, stirring constantly (looks like very liquid pudding). Do not boil! Let cool to room temperature, add cream and chill. Add rum raisins just before the end of the freezing process.

Yoghurt Lemon Ice

1 1/4 cups (310 ml) plain yoghurt

3 tbs. (45 ml) heavy cream

3/4 cup (175 ml) sugar

1 cup (250 ml) lemon juice

Mix yoghurt, cream and sugar until sugar is dissolved. Add lemon juice and stir in.

Yoghurt Berry Ice

1/2 cup (125 ml) strawberries

1/2 cup (125 ml) raspberries

1/2 cup (125 ml) blackberries

1 cup (250 ml) plain yoghurt

1/2 cup (125 ml) sugar

Wash berries, remove stems and puree in a blender. Mix yoghurt and sugar until sugar is dissolved. Stir in fruit puree.

Iced Strawberry Soufflé

1 3/4 cup (425 ml) strawberries

3 egg yolks

1/4 cup (60 ml) sugar

1 cup (250 ml) buttermilk

Wash strawberries, remove stems and puree in a blender. In a small pan slowly heat egg yolks together with 2 tbsp. (30 ml) of puree until it becomes granular. In a chilled bowl mix thoroughly the egg-mixture with all the strawberry puree. Add buttermilk and sugar.

Orange Sorbet

1 1/4 cup (310 ml) sugar

1 1/4 cup (310 ml) water

1 3/4 cup (425 ml) orange juice

Mix water and sugar in a pan and bring to a boil. Let mixture cool to room temperature. Stir in orange juice and chill.

Variations:

You can also substitute lemon or grapefruit juice or pureed Kiwis (add 1 tbsp. (15 ml) lemon juice).

Honey-Grapefruit Sorbet

3/4 cup (175 ml) honey

2 cups (500 ml) grapefruit juice

In a small pan over low heat warm the honey until lukewarm. Mix in 4 tbsp. (60 ml) of juice. In a separate bowl combine honey-mixture and remaining juice.

Ice Milk

2 cups (500 ml) milk
2/3 cup (150 ml) sugar
3 eggs
1 cup (250 ml) cream

Mix eggs and sugar with a beater in a saucepan. Add milk. Stirring constantly heat the mixture to 195 °F/90 °C. Do not boil! Let cool to room temperature and stir in cream. Chill.

The following ingredients can also be added:

- 1 tbsp. (15 ml) cinnamon
- 1 tbsp. (15 ml) instant coffee
2 tbsp. (30 ml) almond extract

Base Mixture for Ice Cream

2 cups (250 ml) milk
4 egg yolks
1 tsp. (5 ml) corn starch
1/2 cup (125 ml) sugar

Bring milk in a pan to a boil. Beat egg yolks, sugar and starch in a bowl until mixture is nearly white. Pour the hot milk into mixture, constantly stirring. Return mixture to pan and heat, continuing to stir, until it slightly thickens. Do not boil! Chill.

To this base mixture you can add:

3 pureed bananas
1/2 cup (125 ml) roasted almonds
2/3 cup (150 ml) chopped hazelnuts
1/2 cup (125 ml) chocolate chips

Frozen Pina Coladas

one 8 oz. (250 g) can cream of coconut
2 1/2 cups (625 ml) unsweetened pineapple juice
1/2 cup (125 ml) dark rum
Combine all ingredients.

Frozen Margaritas

2 1/3 cups (575 ml) water
1/2 cup (125 ml) lime juice
3/4 cup (175 ml) triple sec
2/3 cup (150 ml) tequila
Combine all ingredients.

Limited One Year Warranty

Your KRUPS #358 is covered by the following warranty:

If from date of purchase within one year this KRUPS product fails to function because of defects in materials or workmanship, KRUPS North America will, at its option, repair or replace the unit without charge, provided the owner has a proof of date of purchase.

This warranty will be void if malfunction was caused by damage to the product by accident, misuse, use on frequency or voltage other than marked on the product and/or described in the instructions, abuse including tampering, damage in transit, or use for commercial purposes. This warranty gives you specific legal rights, and you may also have other rights which may vary from state to state.

GUARANTEE OF PERFORMANCE

This fine KRUPS product is manufactured according to a rigid code of quality standards, and, with minimum care, should give years of satisfying service.

However, should the need arise for repairs or for replacement parts within or after the warranty period, please call our **CONSUMER SERVICE DEPARTMENT**:

(800) 526-5377
24-hours a day, 7 days a week

You will be provided with specific instruction on how to get your product repaired, as well as the name and address of your nearest authorized KRUPS Service Center. The department will also be able to answer any general product questions you may have.

Before calling the Consumer Service Department, please have the type number of your KRUPS appliance available. You must have this information before calling our Consumer Service Department so that we may better answer your questions. The type number can be located by looking at the bottom of your appliance.

This product is Type #358

Any general correspondence can be addressed to:

KRUPS North America, Inc.
P.O. Box 3900
Peoria, IL 61612