



Welcome to use SMD REWORK SOLDERING STATION/KADA 852 Produced by our factory. It is specially designed for higher efficiency and saving your time. It is very convenient to shift a switch for the separate function of electrical tip soldering and hot air solde ring or combined functions with flexibility and high efficiency.

Please read this manual carefully before you use it.

Package list

Please check and confirm the following items in the package when you purchase

Item	quantity
852	1
Soldering tip	1
Soldering tip stand	1
(Sponge for cleaning is included)	1
Holder for handle of hot air soldering head	1
Manual	1

△ WARNING:

- 1) Remove the pump securing screw (M5*10, red). Otherwise it will cause big problem.
- 2) Read this manual carefully before you use this machine.
- 3) Ground must be connected for prevention of static release before use.
- 4) Don't damage the piece against removal. Otherwise guaranteed service will be invalid.
- 5) Don't put any other metal article near the soldering tip net. Otherwise damage or electric shock will be caused.
- 6) Please contact with the supplier if the machine is in trouble. Be sure to lock the pump securing screw in red at the bottom of the machine before the delivery.

NAMES OF PARTS:

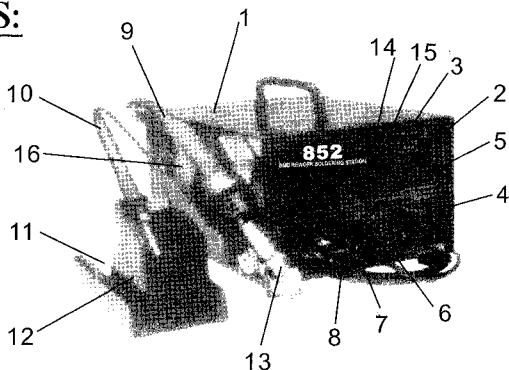

- 1) Shell of the machine 2) Switch of air control 3) Air flow indicator
4) Switch of temperature control (see temperature chart) 5) Indicator of temperature (it will be on during normal working period) 6) Switch for temperature setting of the tip 7) Indicator of the tip (it will be on when the temperature is high enough) 8) Plug of the tip 9) Handle of the hot air gun
10) Handle of the tip 11) Sponge for cleaning of the tip 12) Stand for the tip 13) Hot air welding head for removal 14) Power switch for soldering tip
15) Power switch for the tip. 16) Holder for the handle of the soldering head

BEFORE USE

- 1) Release the pump securing screw
Release the pump securing screw (M5*10 red) at the bottom of the machine 852. Otherwise it will cause big problem.
- 2) Select nozzle with the dimension compliant to the integrated circuit unit.
Install the nozzle when the heating tube and the nozzle are cool down to make sure the temperature is safe to people.

Installation of the nozzle;

- 1) Release the screw of the nozzle.
- 2) Install the nozzle into position.

Don't install the nozzle with too much strength, neither install it pulling the edge with a forceps, nor too much strength to drive the screw.

Cautions:

- 1) Heat protector
For safety, the power will automatically shut off when the temperature is high enough and will be on again when the temperature is safe. Switch the power on to cool down the hot air head, lower down the set temperature or increase the air flow to continue working. You must

shut off the power if the temperature protector is in trouble or you don't want to continue the work or you want to leave the station.

2) Be careful, it is high temperature.

Never use 852 when it is close to flammable gas or other material like paper. Both the nozzle and the air are in high temperature. Never touch the hot nozzle or blow the body skin directly, It smokes a little bit when you switch on the power. But after a while the smoke will disappear.

3) After use it, don't forget to cool down the body of the machine.

After shut off the power, the heating tube will blow cool air for a little while. During this period, don't unplug the plug.

4) Dropping down or shaking violently

Heating tube contains quartz. Dropping down or shaking violently would break the glass.

5) Don't dismantle the pump.

6) If the machine will not be used for a long time, unplug the plug.

If the machine is plugged, there will be some current input even if you switch the power off, So if it is not used for long time, the plug must be unplugged.

INSTRUCTIONS:

QFP tin removal process

1) Plug the power

After the power line is plugged, the auto air - blow function will be actuated. But the heating material is still in a cool state.

2) Switch on the power

When the auto air - blow function is actuated, you can switch the power on. After that the heating material will heat.

3) Adjust the air blow and the switch of temperature control.

After adjustment of the air blow and the temperature switch, wait a little while for stability of the temperature (Please see the temperature chart). We suggest to adjust the temperature between 250 - 300°C. For air flow control, if it is single nozzle, you can set it at 1-3 shift and other nozzles at 4 - 6 shift. With single nozzle, the maximum shift of temperature control is at 6 shift.

4) Install the puller under the integrated circuit unit.

If the width of the unit is not compliant with the dimension of the wire, you can depress the wire for installation.

5) Melt the soldering material

Hold the soldering head, aim at the soldering material. The hot air will melt the soldering material. Don't touch the line of the integrated unit with the nozzle.

6) Remove the integrated unit

When the soldering material melted, remove the integrated unit away.

7) Switch off the power

After you switch off the power, the auto air - blow function will be actuated. Cool air will be conveyed through the tube for cooling the heating material and the handle. So don't unplug the plug during this time. If you don't use the machine for a long time later, unplug the plug.

8) Remove the superabundant soldering material.

After removal of the integrated unit, the superabundant soldering material could be taken away by the cleaner. NOTE: if it is SOP; PLCC, You can lift the integrated unit with a clip.

QFP soldering

1) Coat with some soldering paste

Coat with some soldering paste, and put the SMD on the circuit unit.

2) Pre - heat SMD

3) Soldering

Spray hot air to the line frame.

4) Cleaning

After welding, clean the superabundant soldering material.

NOTE: To weld with hot air is effective. But it may cause soldering material ball or cause connection of the material. We suggest you to check the soldering unit.

REPLACE THE HEATING MATERIAL

- 1) Unscrew the screw and remove the heating material.

Release 3 screws in the handle (see fig. 1-1, 2, 3,) and release the heating material.

- 2) Open the handle

Release the termination of the ground connection (see fig. 2-1) and take out the tube. There is quartz glass and isolation material inside. Don't drop them or get them lost.

- 3) Take out the heating material

Release the inserted termination (see fig. 2-2) and take out the heating material.

- 4) Insert new heating material

Install it carefully, don't scratch the heating material. Assemble the handle in a reverse process when open it. Insert the rise high part into the tube.

HEATING UNIT DEMONSTRATION

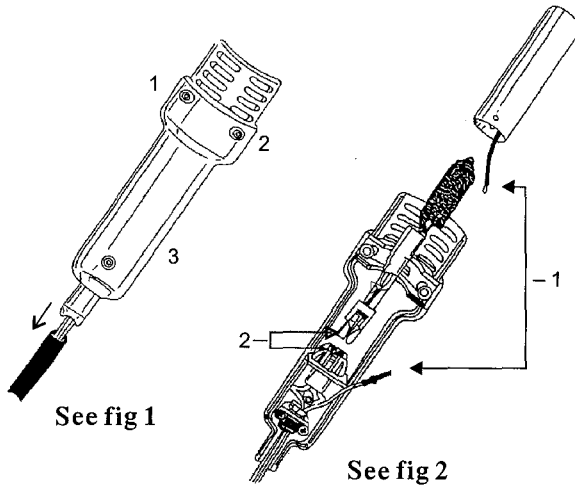

TEMPERATURE CHART

Classification of measurement: (A1124) 3 mm to the air - blow nozzle, it is measured by a recorder.

The room temperature is 23°C.

The diameter of A1124 single tube is 2.5 (0.09 inch)

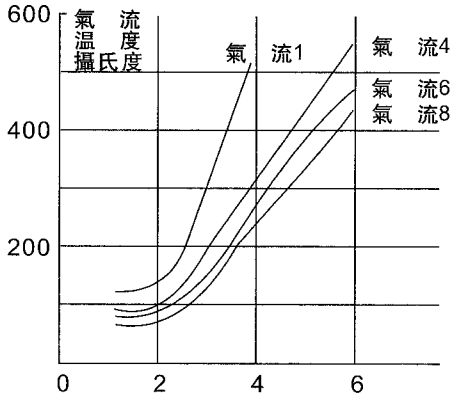

Temperature control switch

1. CAUTIONS



Caution

When the power is on, the temperature of the soldering head is 200-480°C. Any mis - use may cause injury to people or fire. Please follow the instructions below strictly:

- ※ Don't touch the metal near the soldering head.
- ※ Don't use the soldering iron head near flammable material.
- ※ Inform all the workers on site that the soldering head is very hot and in may cause serious accident; power must be switch off during break hour and after work.
- ※ Always replace or install the soldering iron head after switch off the power and wait until the iron head is cool down to room temperature.

For protection of the soldering station and maintain a safety working environment, please follow the instruction below:

- ※ Don't use the soldering iron head for non-soldering purpose.
- ※ Don't knock the soldering iron head at working table for cleaning the superabundant soldering material. It will damage the soldering iron head seriously.
- ※ Don't try to alter the soldering station without authorization. If replacement of part is necessary, always use the original.
- ※ Don't get the soldering station wet and don't use the soldering station when your hand is wet.
- ※ There will be smoke during soldering process. Ventilation equipment should be installed in the work place.
- ※ Don't do anything may cause body injury or damage of objects.

2. INSTALLATION AND USE OF SOLERING IRON TIP

A. Soldering tip stand

- △ Caution: sponge can be depressed. Before you use it for cleaning, let it absorb water and then depress it try. Otherwise it will damage the soldering tip.

B. Joint

- △ Cautions: Before connection and dismantle the soldering station, be sure to switch the power off so that the print circuit will not be damaged.

1. Connect the power line to the outlet.
2. Place the soldering tip on the stand.
3. Plug the outlet for power. Don't forget ground connection.

C. Setting of temperature

When the temperature rises to the set, the indicator of the heater will flash, indicating you can start soldering.

- △ Caution: when you are not using the soldering tip, it should be put on the stand.

3. MAINTENANCE AND USE OF THE SOLDERING TIP

- ※ Temperature of the soldering tip---High temperature will decrease the function of the soldering tip. So the temperature should be set at the lowest. This soldering tip has good quality for recovery and can solder at low temperature. This can protect the component sensitive with temperature.
- ※ Cleaning-----The tip should be cleaned with sponge periodically. After soldering, the oxidized and carbonated superabundant soldering material will damage the tip. Deviation of soldering and deduction of function of the soldering tip will be occur. The soldering tip must be dismantled for cleaning every week so that the soldering tip can keep the function.
- ※ Not use at the moment-----When the iron tip is not used, it can not be kept in high temperature state. High temperature will make the soldering material on the tip oxidized and decrease the heat conduct function of the tip.

4. MAINTENANCE

Check and clean the iron tip

Caution : Never clean the tip with a file.

1. Set the temperature at 250°C.
2. When the temperature is stable, clean the tip with a sponge and check the tip.
3. If the tin coated on the tip turned black, coat it again with new tin and clean it with the sponge. Do it again and again until the oxidized cleaned and coat it with new tin.
4. If the tip is distorted or badly rusted, replace it with a new one.

5. ADJUST THE TEMPERATURE OF THE TIP

After you replace the iron tip or heater, the temperature should be adjusted again. The temperature of the tip is different from the type due to conduction and release of heat. Please see the following chart for the difference.

Tips

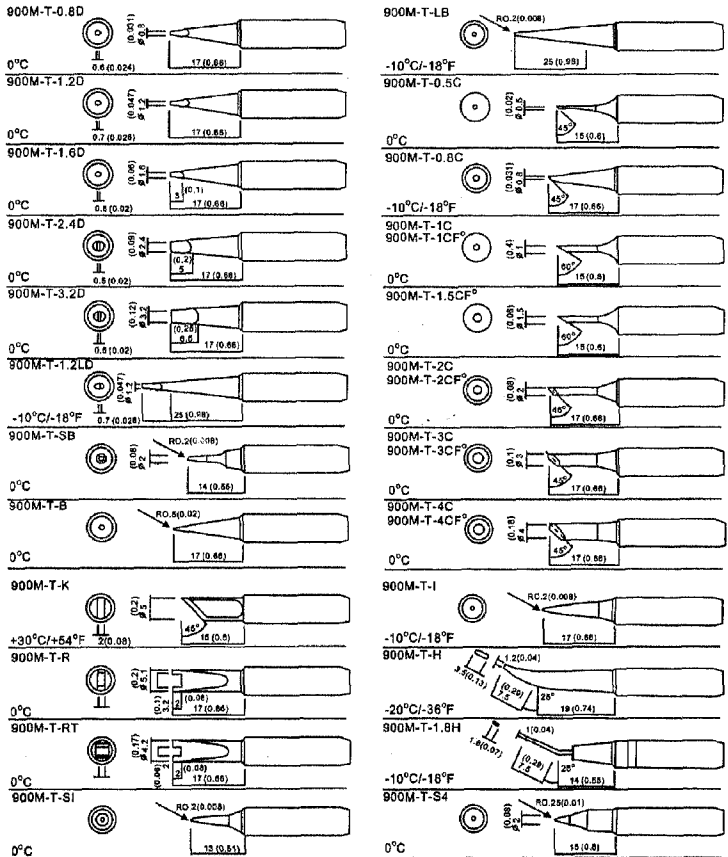

900M-tip Out Diam ϕ 6.5 900M 型焊铁头外径为 ϕ 6.5

Please contact us for different types of tips.

Dimensions of renewable nozzles.

Indicate the flat IC dimension (.....).(mm).

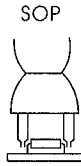
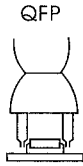
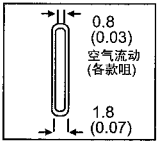

A1124
单独式



A1125
QFP10×10(0.39×0.39)

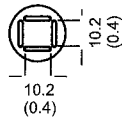

A1126
QFP14×14(0.55×0.55)

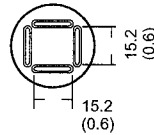

A1127
QFP17.5×17.5(0.68×0.68)

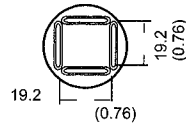

A1128
QFP14×20(0.55×0.78)

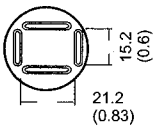

A1129
QFP14×28(1.1×1.1)

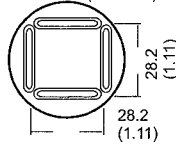

A1130
单独式



A1131
SOP4.4×10(0.17×0.39)

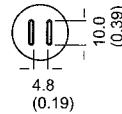

Hot air soldering station	Specifications
Specified voltage	110V
Consumption	270W
Type of pump	Membranous
Air flow	0.3-24L /min. Adjustable
Pump power	45W
Heater	250W metal
Hot air temp.	100℃-420℃

Soldering station	Specifications
Power	60W
Output voltage	24V/AC
Temp. Range	200-480°C
Bulk	187 mm*135mm*245mm
Weight	4Kg

If any change of the above design or specification,
Customers will not be informed respectively.